



Harmonics and Harmonic Mitigating Transformers (HMT's) Questions and Answers

This document has been written to provide answers to the more frequently asked questions we have received regarding harmonics and the Harmonic Mitigating Transformer technology used to address them. This information will be of interest to both those experienced in harmonic mitigation techniques and those new to the problem of harmonics. For additional information visit our Website at www.mirusinternational.com.

1. [What are non-linear loads and why are they a concern today?](#)
2. [Do different types of non-linear loads generate different harmonics?](#)
3. [Why do non-linear loads have low power factors and why is it important to have a high power factor?](#)
4. [What is an SMPS and how does it generate harmonics?](#)
5. [Can't equipment manufacturers design their products to be free of harmonics?](#)
6. [What problems do non-linear loads and harmonics create?](#)
7. [Why do 3rd harmonic currents overload neutral conductors?](#)
8. [How do non-linear loads create current and voltage harmonics?](#)
9. [What ill effects do the harmonics created by computer power supplies have on themselves?](#)
10. [How do harmonics increase power losses and overheat transformers?](#)
11. [What are zero sequence harmonic filters and how do they reduce 3rd harmonic and prevent neutral conductor overheating?](#)
12. [What is an Harmonic Mitigating Transformer and how is it different than a K-rated Transformer?](#)
13. [How do Harmonic Mitigating Transformers reduce voltage distortion?](#)
14. [How do Harmonic Mitigating Transformers save energy?](#)
15. [What constitutes an EPA Energy Star Transformer and is it important when supplying non-linear loads?](#)
16. [How reliable are transformer energy efficiency tests \(including Independent 3rd Party\) under non-linear loading?](#)
17. [Am I not safe from harmonics if I use K-Rated transformers and oversized neutrals?](#)
18. [Are there standards that can help in addressing harmonics?](#)
19. [Can neutral currents, such as the 3rd harmonic, be reduced by the use of 3rd Harmonic Blocking Filters?](#)

[<Back to Questions>](#)

1. What are non-linear loads and why are they a concern today?

A load is considered non-linear if its impedance changes with the applied voltage. The changing impedance means that the current drawn by the non-linear load will not be sinusoidal even when it is connected to a sinusoidal voltage. These non-sinusoidal currents contain harmonic currents that interact with the impedance of the power distribution system to create voltage distortion that can affect both the distribution system equipment and the loads connected to it.

In the past, non-linear loads were primarily found in heavy industrial applications such as arc furnaces, large variable frequency drives (VFD), heavy rectifiers for electrolytic refining, etc. The harmonics they generated were typically localized and often addressed by knowledgeable experts.

Times have changed. Harmonic problems are now common in not only industrial applications but in commercial buildings as well. This is due primarily to new power conversion technologies, such as the Switch-mode Power Supply (SMPS), which can be found in virtually every power electronic device (computers, servers, monitors, printers, photocopiers, telecom systems, broadcasting equipment, banking machines, etc.). The SMPS is an excellent power supply, but it is also a highly non-linear load. Their proliferation has made them a substantial portion of the total load in most commercial buildings.

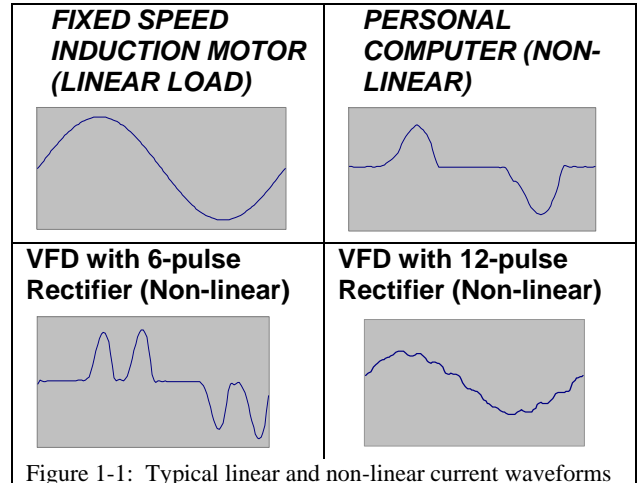

Examples of the current drawn by various types of equipment are shown in Figure 1-1. The most common form of distorted current is a pulse waveform with a high crest factor. The SMPS is one such load since it consists of a 2-pulse rectifier bridge (to convert AC to DC) and a large filter capacitor on its DC bus. The SMPS draws current in short, high-amplitude pulses that occur right at the positive and negative peaks of the voltage. Typically these high current pulses will cause clipping or flat-topping of the 120VAC supply voltage. The “double-hump” current waveform of the 6-pulse rectifier in a UPS or a VFD also will cause clipping or flat-topping of the 480V or 600V distribution system. Further discussions on voltage flat-topping and its effect on connected equipment can be found in answers to Questions 8 and 9.

[<Back to Questions>](#)

2. Do different types of non-linear loads generate different harmonics?

By far the majority of today's non-linear loads are rectifiers with DC smoothing capacitors. These rectifiers typically come in 3 types – (i) single phase, line-to-neutral, (ii) single phase, phase-to-phase and (iii) three-phase.

Single-phase line-to-neutral rectifier loads, such as switch-mode power supplies in computer equipment, generate current harmonics 3rd, 5th, 7th, 9th and higher. The 3rd will be the most predominant and typically the most troublesome. 3rd, 9th and other odd multiples of the 3rd harmonic are often referred to as triplen harmonics and because they add arithmetically in the neutral are also considered zero sequence currents. Line-to-neutral non-linear loads can be found in computer data centers, telecom rooms, broadcasting studios, schools, financial institutions, etc.

208V single-phase rectifier loads can also produce 3rd, 5th, 7th, 9th and higher harmonic currents but if they are reasonably balanced across the 3 phases, the amplitude of 3rd and 9th will be small. Because they are connected line-line, these loads cannot contribute to the neutral current. The largest current and voltage harmonics will generally be the 5th followed by the 7th. Typical single phase, 208V rectifier loads include the switch-mode power supplies in computer equipment and peripherals.

Three-phase rectifier loads are inherently balanced and therefore generally produce very little 3rd and 9th harmonic currents unless their voltage supply is unbalanced. Their principle harmonics are the 5th and 7th with 11th and 13th also present. They cannot produce neutral current because they are not connected to the neutral conductor. The rectifiers of variable speed drives and Uninterruptible Power Supplies (UPS) are typical examples of three-phase rectifier loads.

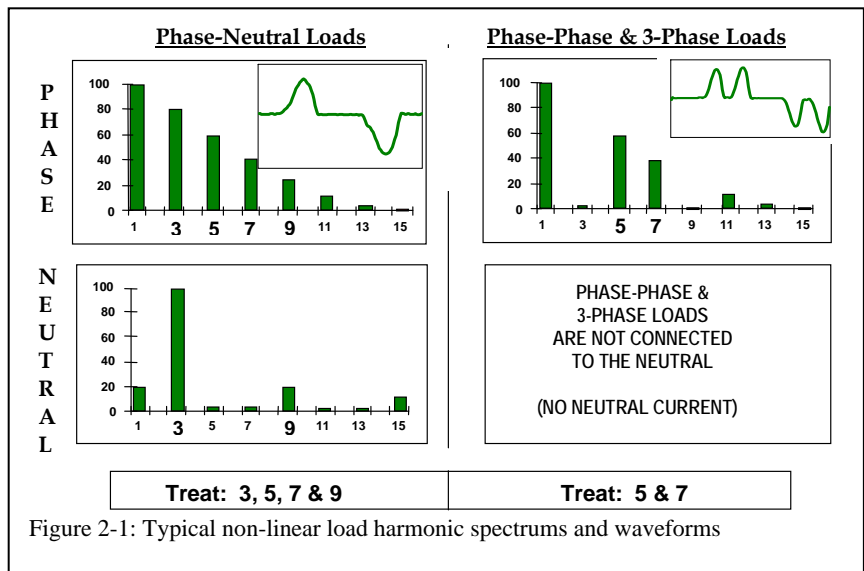

Figure 2-1: Typical non-linear load harmonic spectrums and waveforms

[<Back to Questions>](#)

3. Why do non-linear loads have low power factors and why is it important to have a high power factor?

Power factor is a measure of how effectively a specific load consumes electricity to produce work. The higher the power factor, the more work produced for a given voltage and current. Figure 3-1 shows the power vector relationships for both linear and non-linear loads. Power factor is always measured as the ratio between real power in kilowatts (kW) and apparent power in kilovoltamperes (kVA).

For linear loads, the apparent power in kVA ($S = V \cdot I$) is the vector sum of the reactive power in kVAR (Q) and the real power in kW (P). The power factor is $P/S = \cos\Phi$, where Φ is the angle between S and P. This angle is the same as the displacement angle between the voltage and the current for linear loads. For a given amount of current, increasing the displacement angle will increase Q, decrease P, and lower the PF. Inductive loads such as induction motors cause their current to lag the voltage, capacitors cause their current to lead the voltage, and purely resistive loads draw their current in-phase with the voltage. For circuits with strictly linear loads (a rare situation) simple capacitor banks may be added to the system to improve a lagging power factor due to induction motors or other lagging loads.

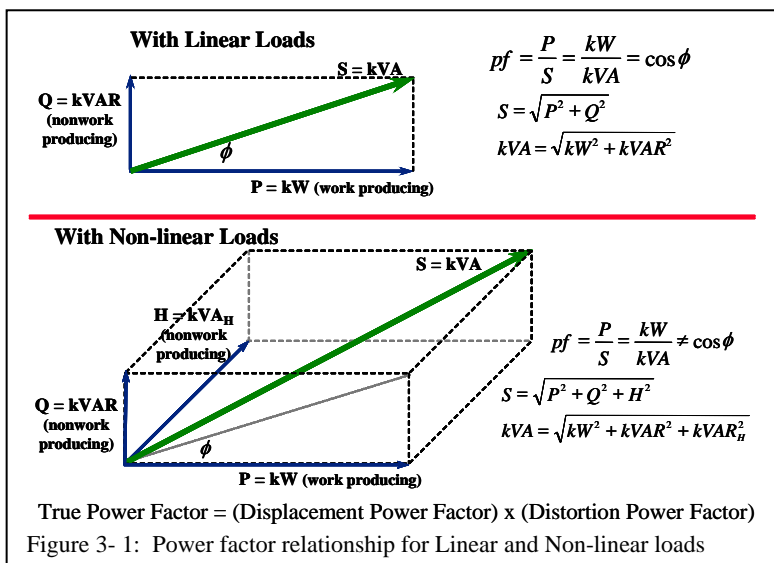

Figure 3- 1: Power factor relationship for Linear and Non-linear loads

For non-linear loads, the harmonic currents they draw produce no useful work and therefore are reactive in nature. The power vector relationship becomes 3 dimensional with distortion reactive power, H, combining with both Q and P to produce the apparent power which the power system must deliver. Power factor remains the ratio of kW to kVA but the kVA now has a harmonic component as well. True power factor becomes the combination of displacement power factor and distortion power factor. For most typical non-linear loads, the displacement power factor will be near unity. True power factor however, is normally very low because of the distortion component. For example, the displacement power factor of a personal computer will be near unity but its total power factor is often in the 0.65 – 0.7 range. The best way to improve a poor power factor caused by non-linear loads is to remove the harmonic currents.

Most Utilities charge their customers for energy supplied in kilowatt-hours during the billing period plus a demand charge for that period. The demand charge is based upon the peak load during the period. The demand charge is applied by the utility because it must provide equipment large enough for the peak kVA demand even though the customer's power demand may be much lower. If the power factor during the peak period (usually a 10 minute sliding window) is lower than required by the utility (usually 0.9 or 0.95), the utility may also apply a low PF penalty charge as part of the demand charge portion of the bill.

Suppose the peak demand was 800kW with apparent power consumption of 1000kVA (a PF of 0.8). If a power factor penalty was applied at 0.9, the Utility would charge the customer as if his demand was 0.9 x 1000kVA = 900kW even though his peak was really 800kW, a penalty of 100kW. Improving the power factor to 0.85 at 1000kVA demand would lower the penalty to just 50kW. For power factors of 0.9 to 1.0, there would be no penalty and the demand charge would be based upon the actual peak kW. The demand charge is often a substantial part of the customer's overall power bill, so it is worthwhile to maintain good power factor during peak loading and reducing the harmonic current as drawn by the loads can help achieve this.

References:

1. Roger C. Dugan, *Electrical Power Systems Quality*, McGraw-Hill, New York NY, 1996, pp. 130-133
2. H. Rissik, *The Fundamental Theory of Arc Convertors*, Chapman and Hall, London, 1939, pp 85-97

[<Back to Questions>](#)

4. What is an SMPS and how does it generate harmonics?

The Switch-mode Power Supply (SMPS) is found in most power electronics today. Its reduced size and weight, better energy efficiency and lower cost make it far superior to the power supply technology it replaced.

Electronic devices need power supplies to convert the 120VAC receptacle voltage to the low voltage DC levels that they require. Older generation power supplies used large and heavy 60 Hz step-down transformers to convert the AC input voltage to lower values before rectification. The SMPS avoids the heavy 60 Hz step-down transformer by directly rectifying the 120VAC using an input diode bridge (Figure 4-1). The rectified voltage is then converted to lower voltages by much smaller and lighter switch-mode dc-to-dc converters using tiny transformers that operate at very high frequency. Consequently the SMPS is very small and light.

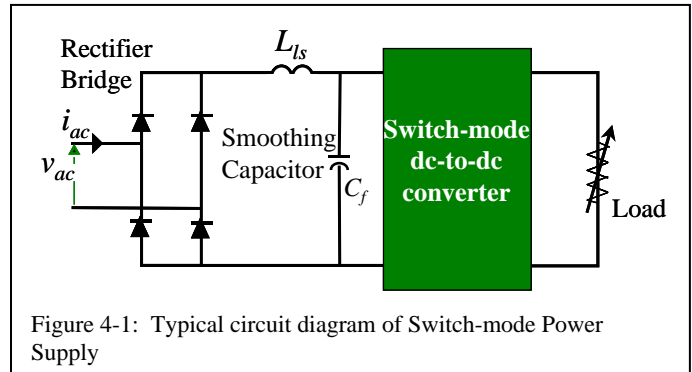

Figure 4-1: Typical circuit diagram of Switch-mode Power Supply

The SMPS is not without its downside, however. The operation of the diode bridge and accompanying smoothing capacitor is very non-linear in nature. That is, it draws current in non-sinusoidal pulses at the peak of the voltage waveform (see Figure 4-2). This non-sinusoidal current waveform is very rich in harmonic currents.

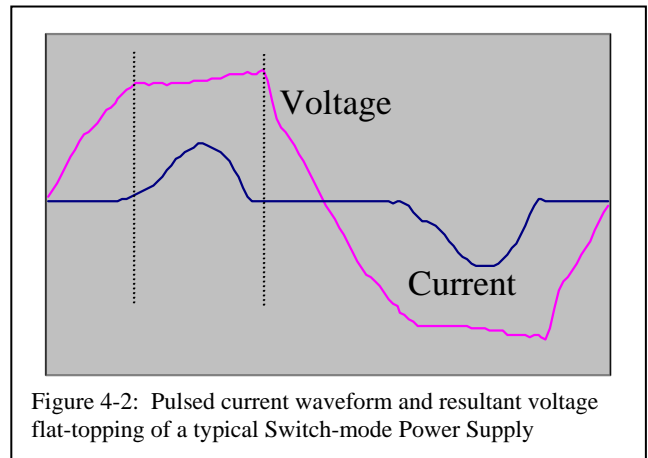

Figure 4-2: Pulsed current waveform and resultant voltage flat-topping of a typical Switch-mode Power Supply

Because the SMPS has become the standard computer power supply, they are found in large quantities in commercial buildings. Acting together, the multitude of SMPS units can badly distort what started out as a sine wave voltage waveform.

Twice per cycle every SMPS draws a pulse of current to recharge its capacitor to the peak value of the supply voltage. Between voltage peaks the capacitor discharges to support the load and the SMPS does not draw current from the utility. The supply voltage peak is flattened by the instantaneous voltage drops throughout the distribution system caused by the simultaneous current pulses drawn by the multiple SMPS units. The expected sine wave with a peak of $120 \times \sqrt{2} = 169.4V$ instead starts to resemble a square wave. The flattened voltage waveform contains a lowered fundamental voltage component plus 3rd, 5th, 7th, 9th and higher voltage harmonics.

For an alternate view of the relationship between current harmonics, voltage harmonics, Ohm's Law, and non-linear loads, please see Question 8.

[<Back to Questions>](#)

5. Can't equipment manufacturers design their products to be free of harmonics?

Yes they can, but lowering the current distortion levels at the input to the SMPS in a computer will add to the cost of the computer. This is not a step that computer manufacturers wish to take because of the continuous and intense cost cutting in the computer industry.

Actually it is less costly overall to provide a harmonic mitigating transformer to feed several hundred computers than it is to improve the operation of the SMPS in each computer. This is especially true when we consider that the added cost of the improved SMPS will reappear every three years when a new computer system is purchased.

[<Back to Questions>](#)

6. What problems do non-linear loads and harmonics create?

Most power systems can accommodate a certain level of harmonic currents but will experience problems when they become a significant component of the overall load. As these higher frequency harmonic currents flow through the power system, they can create problems such as:

- Overheating of electrical distribution equipment, such as cables, transformers, standby generators, etc.
- Overheating of rotating equipment, such as electric motors
- High voltages and circulating currents caused by harmonic resonance
- Equipment malfunctions due to excessive voltage distortion
- Increased internal losses in connected equipment resulting in component failure and shortened lifespan
- False operation of protection equipment
- Metering errors
- Lower system power factor preventing effective utilization
- Voltage regulator problems on diesel generators
- Inability of automatic transfer switches to operate in closed transition

Harmonics overheat equipment by several means. For example, in electric machines and transformers, harmonic currents cause additional power losses by (i) increasing the eddy currents that flow in their laminated cores, (ii) through increased leakage currents across insulation and (iii) by producing skin effect in conductors. For additional information on how harmonics increase power losses and overheat transformers see Question 10.

The incidence of hot transformers and neutral conductors has been especially common. Even under less than full load conditions, a transformer can run surprisingly hot. One of the reasons is its winding configuration. The overwhelming majority of distribution transformers are DELTA primary, GROUNDED WYE secondary. The delta winding has some undesirable characteristics when significant amounts of 3rd harmonic (and other zero sequence currents) are present on the load side. These harmonics return along the neutral conductor and are trapped in the primary DELTA winding where they circulate causing significant extra heating. They do not flow through to the primary system, but they also are NOT cancelled (Figure 6-1).

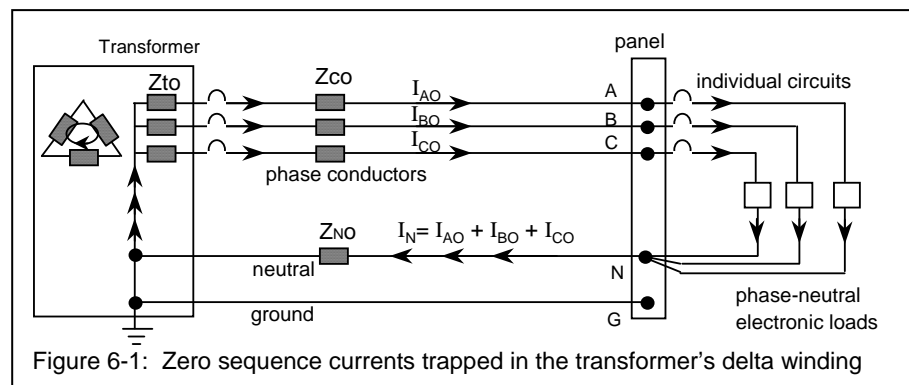

Figure 6-1: Zero sequence currents trapped in the transformer's delta winding

Since additional heating will reduce the life-span of a transformer, it must either be derated (not operated at its full nameplate rating), built to tolerate this additional heating (K-rated transformer) or designed to prevent the primary side circulating currents from being induced (harmonic mitigating transformer). A guide for derating has been proposed by CBEMA (Computer and Business Equipment Manufacturers Association) with the intent to provide users the ability to protect existing transformers which service non-linear loads. The relationship is as follows:

$$\text{Derating Factor} = (1.414 \times \text{RMS load current}) / (\text{PEAK load current})$$

Since many of today's multimeters can measure both peak and TRUE-RMS current, the derating factor can be quickly calculated. When a transformer feeds personal computers and other electronic equipment, typical values range from 0.5 to 0.7 meaning that the transformer should be loaded no more than 50 - 70% of its nameplate full-load rating to prevent damage due to premature aging.

The fact that harmonic currents create voltage distortion as they flow through the power system's impedance makes their impact even more serious. It is voltage distortion, not current distortion, that will affect the connected equipment on the power system. For more on how non-linear loads create voltage distortion and how this can affect connected equipment, see Questions 8 and 9.

[<Back to Questions>](#)

7. Why do 3rd harmonic currents overload neutral conductors?

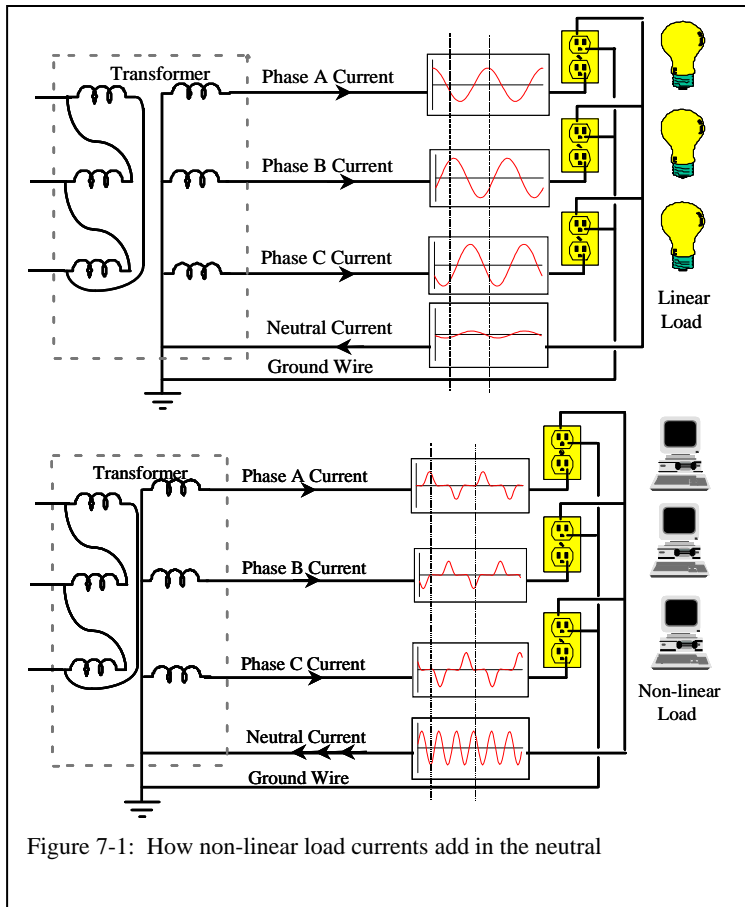

Figure 7-1: How non-linear load currents add in the neutral

Figure 7-1 shows how the sinusoidal currents on the phases of a 3-phase, 4-wire system with linear loads sum to return on the neutral conductor. The 120° phase shift between the sinusoidal load currents causes their vector sum to be quite small. In fact it will be zero if the linear loads are perfectly balanced.

Examining the dashed vertical lines in Figure 7-1 clearly demonstrates that the instantaneous sum of the currents in the three phases taken at any moment will also be zero if the linear loads are perfectly balanced. If they are not, then there will be a small residual neutral current as shown.

With linear loads, the neutral conductor can be the same size as the phase conductors because the neutral current will not be larger than the highest phase current. Unfortunately, this is definitely not true for non-linear phase-to-neutral loads.

120VAC non-linear loads like the SMPS used in computers and in monitors draw current in two distinct pulses per cycle. Because each pulse is narrow (less than 60 degrees), the currents in the second and third phases are zero when the current pulse is occurring in the first phase. Hence no cancellation can occur in the neutral conductor and each pulse of current on a phase becomes a pulse of current on the neutral.

Even if the phase currents of the SMPS loads are perfectly balanced in RMS amperes, the RMS value of the neutral current can be as much as $\sqrt{3}$ times the RMS value of the phase current because there are 3 times as many pulses of current in the neutral than in any one phase. If the phase current pulses do overlap because they exceed 60 degrees in width, then there will be some cancellation so that the neutral current will be less than $\sqrt{3}$ times the phase current. Overlapped or not, because there are 3 times as many pulses in the neutral than in a phase, the predominant component of the neutral current will be the 3rd harmonic (180Hz for a 60Hz system). This is evident in the waveforms of Figure 7-1 since the linear current completes only 2 cycles in the same time period that the non-linear neutral current completes 6 cycles or 3 times the fundamental.

Often, in new construction this situation is addressed by simply doubling the neutral conductor ampacity. In existing facilities however, it is most often very difficult and too costly to implement this solution, therefore an alternate method is usually necessary. Question 11 describes how Zero Sequence Harmonic Filters can be used very effectively to reduce 3rd harmonic currents in the neutral conductor.

[<Back to Questions>](#)

8. How do non-linear loads create current and voltage harmonics?

The switch-mode power supply (SMPS), used in most digital electronic equipment, is an excellent example of a non-linear load. Because it draws current in non-sinusoidal pulses, the SMPS is a significant generator of harmonic currents. When found in high densities multiple SMPS can be a major contributor to voltage distortion. Figure 8-1 shows how the pulsed current consumed by a single-phase SMPS will produce voltage distortion in the form of flat-topping. Since current is consumed only at the peak of the voltage waveform (to charge the smoothing capacitor), voltage drop due to system impedance will also occur only at the peak of the voltage waveform. A flattened voltage peak will reduce the DC bus voltage of the SMPS, reduce its power disturbance ride-through capability, and increase both its current draw and I^2R losses.

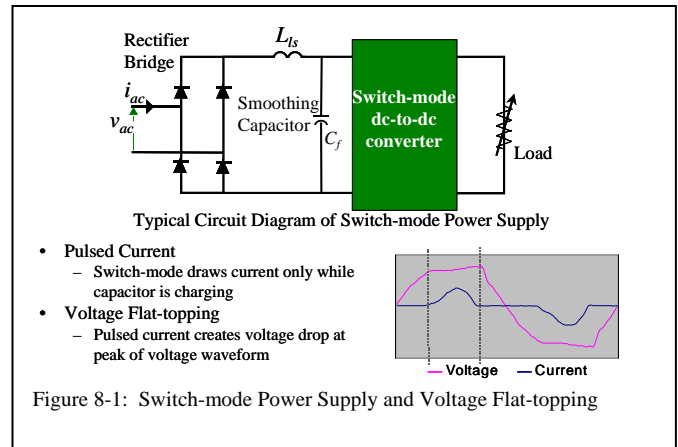

Another way to analyze the operation of the system with non-linear loads is to calculate the effect of each individual harmonic current as it flows through the various impedances of the distribution system. Fourier analysis tells us that the 2-pulse current drawn by the SMPS rectifier has a fundamental frequency component plus all of the odd harmonics (3rd, 5th, 7th, 9th, 11th, etc.) When modeling the distribution system, we can think of each SMPS as a generator of harmonic currents. Each harmonic current injected into the power system by a non-linear load will flow through the system impedance, resulting in a voltage drop at that harmonic frequency. The amount of voltage drop follows Ohm's Law ($V_h = I_h \times Z_h$) where:

- V_h = voltage at harmonic number h
- I_h = amplitude of current harmonic h
- Z_h = impedance of the system to harmonic h.

Figure 8-2 shows the relationship between system impedance and the voltage and current distortion components at several points in a typical power system.

We can calculate the RMS value of the voltage or current distortion if we know the RMS values of all of the components. Parseval's Theorem tells us that the RMS value of a waveform is equal to the square root of the sum of the squares of the RMS values of the fundamental component and all of the harmonic components of the waveform.

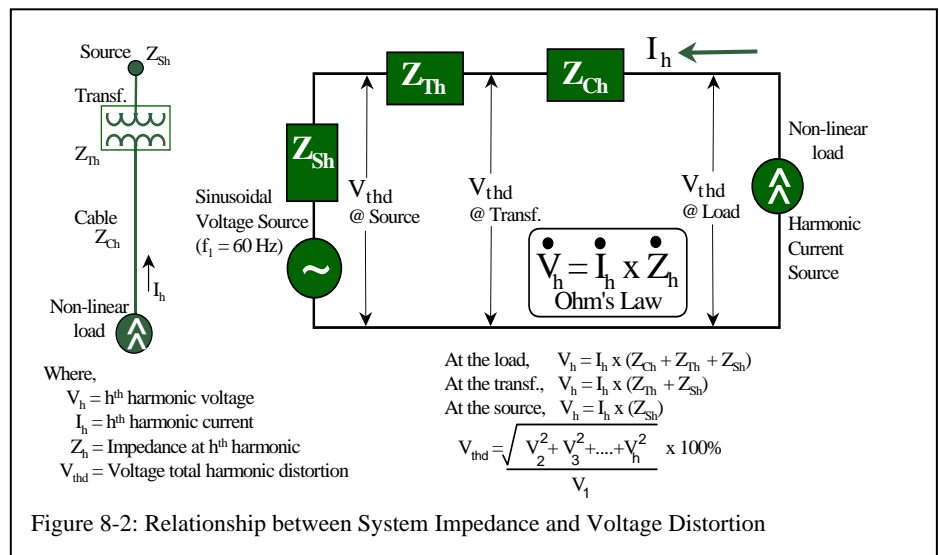

The fundamental is not a distortion component, so the RMS value of the distortion is just the square root of the sum of the squares of the harmonic components. Usually this is expressed as percentage of the value of the fundamental component and is called the *Total Harmonic Distortion*, or *THD*.

[<Back to Questions>](#)

Voltage total harmonic distortion (V_{thd}) is calculated as:

$$V_{thd} = \frac{\sqrt{V_2^2 + V_3^2 + V_4^2 + V_5^2 + \dots}}{V_1} \times 100\%$$

Similarly, current total harmonic distortion is calculated as:

$$I_{thd} = \frac{\sqrt{I_2^2 + I_3^2 + I_4^2 + I_5^2 + \dots}}{I_1} \times 100\%$$

Voltage distortion then is a function of both the system impedance and the amount of harmonic current in the system. The higher the system impedance (ie. long cable runs, high impedance transformers, the use of diesel generators or other weak sources) the higher the voltage distortion.

In Figure 8-2, we see that voltage distortion is greatest at the loads themselves, since the harmonic currents are subjected to the full system impedance (cables, transformer and source) at that point. This is a characteristic most often misunderstood. It means that even if voltage distortion levels are low at the service entrance, they can be unacceptably high at the loads themselves. It also emphasizes the importance of keeping system impedances relatively low when servicing non-linear loads.

Voltage distortion can be minimized by removing the harmonic currents (I_h) and/or lowering the system impedance (Z_h) to the harmonics. (For further information on the relationship between voltage drop and voltage distortion and how to minimize them, we recommend two MIRUS technical papers titled (1) "*Taming the Rogue Wave – Techniques for Reducing Harmonic Distortion*" and (2) "*How the Harmonic Mitigating Transformer Outperforms the K-Rated Transformer*"). For information on how Harmonic Mitigating Transformers reduce voltage distortion see Question 13.

[<Back to Questions>](#)

9. What ill effects do harmonics created by the computer power supplies have on themselves?

As voltage becomes more and more distorted, it will begin to have a negative effect on the connected equipment. A flat-topped voltage waveform can affect a switch-mode power supply (SMPS) in at least 2 major ways:

- A reduced peak voltage will translate to a lower DC bus voltage in the SMPS. Input current to the SMPS will increase because the computer or other electronic load still requires the same amount of power. Increased I²R losses in the SMPS accelerate the aging of its components.
- Power disturbance ride-through capability is reduced since the reduced peak voltage means the large filter capacitor on the DC bus of the SMPS will be able to store much less energy.

When an SMPS is supplied by a voltage waveform with a flattened peak (red trace in Figure 9.1) rather than a nearly pure sinusoidal voltage (blue trace), the DC bus voltage is reduced proportionately (red trace). With a lower DC bus voltage, the SMPS will need to draw more current in order to deliver the same amount of power required by the load ($I = P/V$). This increase in current will result in increased component heating from higher I²R losses and a reduced life expectancy of the components due to their higher operating temperature. For example, a 10% decrease in peak voltage (from 169V to 153V) will increase the SMPS line current by about 11% which will in turn increase the I²R portion of the SMPS losses by about 23%. The correlation of SMPS failures with increased voltage distortion is usually subtle because equipment aging takes time to accumulate.

The first purpose of the large filter capacitor on the DC bus of an SMPS is to reduce the voltage ripple. The second purpose is to support its electronic load during a power interruption or major power dip. Since a typical SMPS is capable of operating for short periods at voltage levels as low as 70%, we can calculate the reduction in ride-through time if the initial voltage stored in the capacitor is below its rated peak voltage. For instance, if the peak voltage supplied to the SMPS is flat-topped by 30%, the ride-through capability is essentially zero and the I²R losses are twice those present at rated peak voltage.

With the correct initial peak voltage, the stored energy in the capacitor will often provide several cycles of ride-through capability before its voltage is reduced to 70% of nominal. This is dramatically reduced however, when the SMPS supply voltage is flat-topped because the energy stored in the capacitor is proportional to the square of the voltage. Figure 9-2 shows how a 10% reduction in the peak voltage supplied to computer equipment will reduce the power dip ride-through time by about 37%. Without the correct peak voltage, the smoothing capacitor in the SMPS will not be fully charged. Initially lower stored energy means that the capacitor will support the load for a much shorter period during a power interruption. When voltage flat-topping becomes severe enough, brief power interruptions such as those characterized by the lights flickering, will begin to affect equipment that would otherwise be unaffected.

In order to ensure reliable operation of power electronic equipment as well as other equipment on the power system, it is important to simultaneously maintain the correct level of both RMS voltage and peak voltage. This can best be achieved by using harmonic mitigation equipment that minimizes voltage distortion throughout the system by removing the harmonic currents from interacting with the upstream supply and distribution equipment.

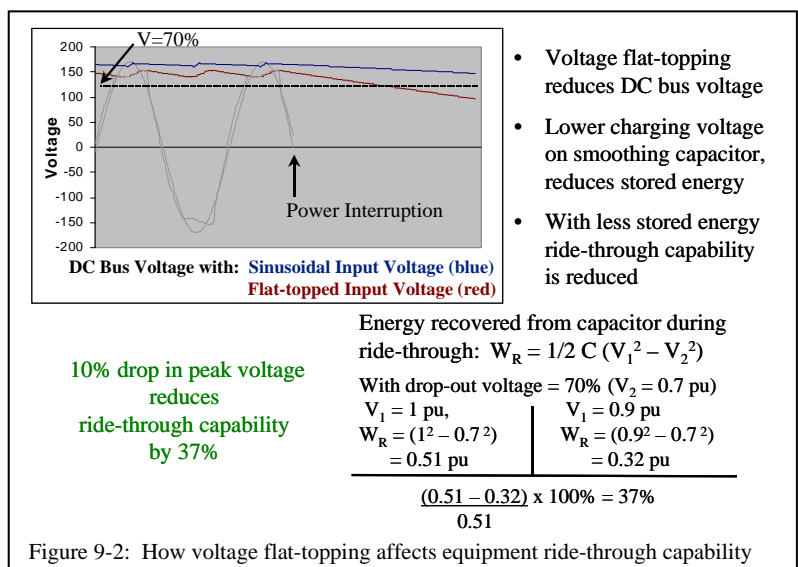
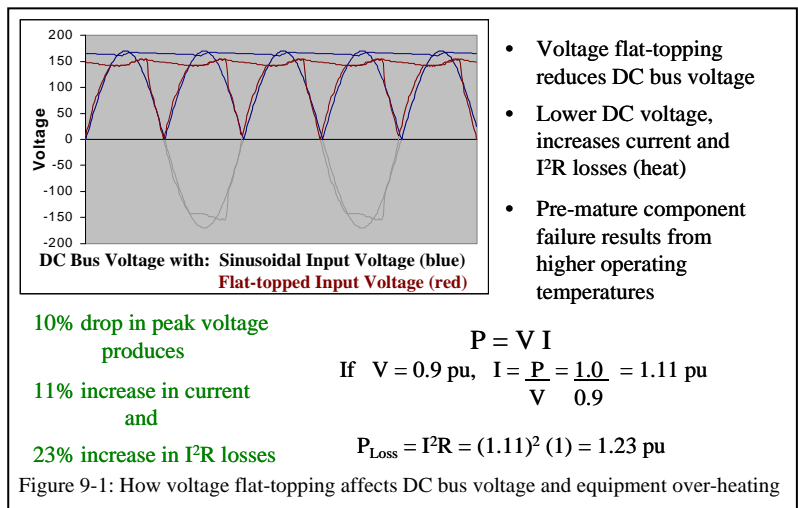

[<Back to Questions>](#)**10. How do harmonics increase power losses and overheat transformers?**

Harmonics generated by non-linear loads substantially increase the losses in conventional or K-rated delta-wye distribution transformers. This increase in losses will increase operating costs and can shorten transformer life. The main thrust of the K-rated design is not to lower the increased losses caused by harmonics but rather to withstand them without overheating.

Transformer loss components include no load (P_{NL}) and load losses (P_{LL}). The no load losses are transformer core losses. They depend mainly upon the peak flux levels reached in the core so the increase in no load losses due to harmonics is usually negligible. On the other hand, load losses are significantly increased by harmonic currents created by non-linear loads.

Load losses consist primarily of I^2R copper losses (P_R) and eddy current losses (P_{EC}). Harmonics increase these losses in the following ways:

1. Copper Losses, I^2R

Harmonic currents are influenced by a phenomenon known as skin effect. Since they are of higher frequency than the fundamental current they tend to flow primarily along the outer edge of a conductor. This reduces the effective cross sectional area of the conductor and increases its resistance. The higher resistance will lead to higher I^2R losses.

2. Eddy Current Losses

Stray electromagnetic fields will induce circulating currents in a transformer's windings, core and other structural parts. These eddy currents produce losses that increase substantially at the higher harmonic frequencies. The relationship is as follows:

$$P_{EC} = P_{EC-1} \sum_{h=1}^{h_{max}} I_h^2 h^2$$

Where:

P_{EC} = Total eddy current losses

P_{EC-1} = Eddy current losses at full load based on linear loading only.

I_h = rms current (per unit) at harmonic h

h = harmonic #

For linear loads, eddy currents are a fairly small component of the overall load losses (typically about 5%). With non-linear loads however, they become a much more significant component, sometimes increasing by as much as 15x to 20x. A transformer can easily be subjected to losses exceeding its full load rating even though the RMS value of the non-linear load current indicates only partial loading.

Because Harmonic Mitigating Transformers (HMT) cancel certain harmonic fluxes without coupling them to the primary windings, their primary winding currents are lower than those found on conventional transformers having the same level of non-linear load currents on the secondary side. This means that the I^2R losses and eddy current losses on the primary of an HMT are considerably reduced compared to those in a conventional transformer.

The conventional and k-rated delta-wye transformers have the same level of 3rd, 5th, 7th, and 9th harmonic currents in their primary windings as in their secondaries. Do not be misled by the low level of triplen harmonics in the feeder conductors to a delta-wye transformer. Checking the delta primary winding itself will show that the same percentage of 3rd and 9th harmonic currents (compared to the fundamental current) are circulating in the delta primary as is present on the wye secondary. This increases the losses and voltage distortion on a delta-wye transformer compared to an HMT.

Checking the primary of an HMT will reveal only residual amounts of 3rd and 9th harmonic current. Even better, checking the primary of a dual output HMT (MIRUS Harmony-2 for example) will show only residual amounts of 3rd, 5th, 7th, and 9th. Hence lower harmonic losses and lower voltage distortion when HMTs are used to feed non-linear loads.

References:

1. Thomas S. Key, *Costs and Benefits of Harmonic Current Reduction for Switch-Mode Power Supplies in Commercial Office Building*, IEEE Transactions on Industry Applications, Vol. 32, No. 5 Sept/Oct 1996, pp. 1017-1024
2. ANSI/IEEE C57.110-1986, Recommended Practice for Establishing Transformer Capability When Supplying Nonsinusoidal Load Currents, American National Standards Institute

[<Back to Questions>](#)

11. What are zero sequence harmonic filters and how do they reduce 3rd harmonic currents and prevent neutral conductor overheating?

Zero sequence currents, in simple terms, are those found in the neutral conductor. They include the unbalanced 60 Hz currents and the 3rd, 9th, 15th and other triplen harmonic currents. Zero sequence currents appear in the neutral because they do not cancel in the way that 60Hz currents cancel. This is due to the fact that the zero sequence component on one phase is always in phase with the zero sequence components of the other 2 phases (for further explanation of this see Question 7). 60 Hz current on one phase, on the other hand, is always 120° out of phase with the other phases 60 Hz current which causes their balanced portions to cancel in the neutral. The windings of a zero sequence filter (ZSF) are connected in a manner that exploits the fact that zero sequence currents are always in phase.

Figure 11-1 shows the windings of a simple ZSF. Here the coils on each phase are split between two core legs and wound in opposite polarity. Since the zero sequence current vectors (A_0 , B_0 and C_0) are always in phase, the flux produced on one coil in each leg will cancel with the flux produced in the second coil on the same leg. Since the zero sequence flux is cancelled, the impedance to the flow of zero sequence currents will be extremely low. When connected in parallel at a power panel or busduct on the power distribution system, the low zero sequence impedance of the ZSF will attract the zero sequence harmonic currents and provide an alternate path back to the loads. This off-loads the neutral conductor and upstream transformer of these currents (see Figure 11-2).

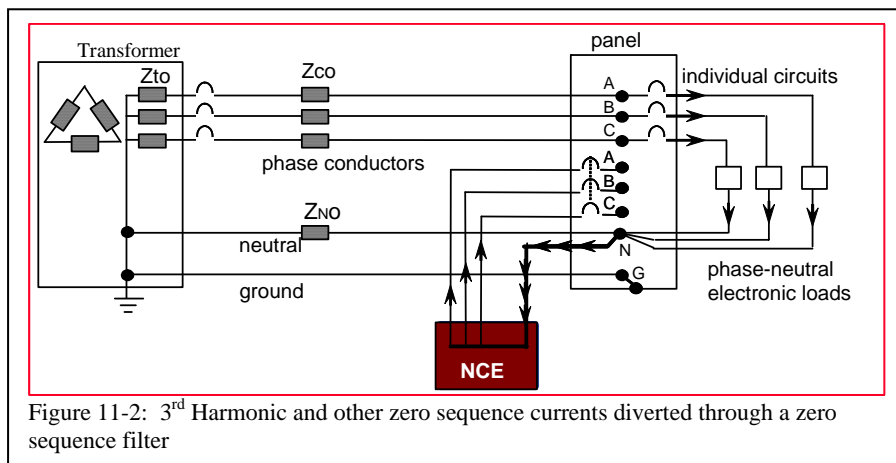
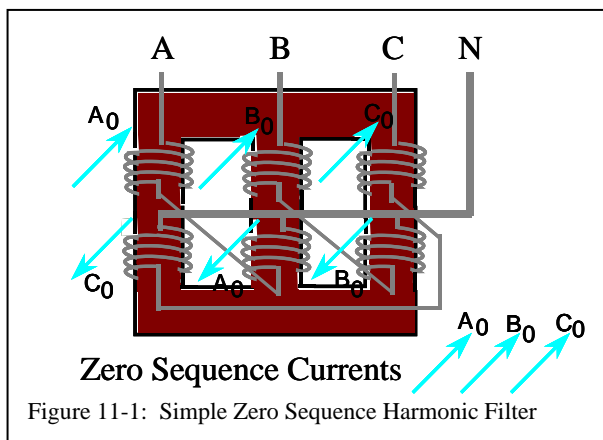

[<Back to Questions>](#)

12. What is a Harmonic Mitigating Transformer and how is it different than a K-Rated Transformer?

Harmonic Mitigating Transformers, or HMTs, are specifically designed to minimize the voltage distortion and power losses that result from the harmonics generated by non-linear loads such as personal computers. K-Rated transformers, on the other hand, are simply designed to prevent their overheating when subjected to heavy non-linear loading but do very little to reduce the harmonic losses themselves and as for voltage distortion, they perform virtually no better than conventional delta-wye transformers.

[<Back to Questions>](#)

13. How do Harmonic Mitigating Transformers reduce voltage distortion?

Delta-wye transformers, even those with a high K-factor rating, generally present high impedance to the flow of harmonic currents created by the non-linear loads. Question 8 showed that the non-linear loads are current sources that push the harmonic currents through the impedances of the system. Any voltage drop across the impedance of the transformer at other than the fundamental frequency (60 Hz) is a component of voltage distortion.

Because of its higher impedance to harmonic currents, the voltage distortion at the output of a delta-wye transformer often reaches the 5% maximum voltage distortion limit recommended by IEEE Std. 519-1992 by the time that the secondary side load has reached just one-half of full-load RMS current. At closer to full-load, these transformers can produce critically high levels of voltage distortion and flat-topping at their outputs and at the downstream loads.

To minimize the voltage distortion rise due to the transformer itself, Harmonic Mitigating Transformers (HMTs) are designed to reduce the impedance seen by the harmonic currents. This is accomplished through zero sequence flux cancellation and through phase shifting - a combined strategy pioneered by MIRUS. The secondary winding configuration of the HMT cancels the zero sequence fluxes (those produced by the 3rd, 9th, 15th (triplen) current harmonics) without coupling them to the primary windings. This prevents the triplen current harmonics from circulating in the primary windings as they do in a delta-wye transformer. The flux cancellation also results in much lower impedance to the zero sequence currents and hence lower voltage distortion at these harmonics. In addition, the reduced primary winding circulating current will lower losses and allow the transformer to run cooler.

The remaining major harmonics (5th, 7th, 11th, 13th, 17th & 19th) are treated to varying degrees through the introduction of phase shifts in the various HMT models.

Single output HMTs are offered in 0° and 30° models to provide upstream cancellation of 5th, 7th, 17th and 19th harmonic currents on the primary feeder.

In a dual output HMT, 5th, 7th, 17th and 19th harmonic current fluxes are cancelled by the 30° phase shift between the secondary windings so that only residual amounts of 5th, 7th, 17th, and 19th current harmonics will be found in the primary side windings.

A three output HMT is configured such that the relative phase shift between the three sets of secondary windings will cancel 5th, 7th, 11th and 13th harmonic fluxes without coupling them to the primary windings.

[<Back to Questions>](#)

14. How do Harmonic Mitigating Transformers save energy?

Harmonic Mitigating Transformers save energy by reducing losses in the following ways:

1. Zero phase sequence harmonic fluxes are canceled by the transformers secondary windings. This prevents triplen harmonic currents from being induced into the primary windings where they would circulate. Consequently, primary side I^2R and eddy current losses are reduced.
2. Multiple output HMT's cancel the balanced portion of the 5th, 7th and other harmonics within their secondary windings. Only residual, unbalanced portions of these harmonics will flow through to the primary windings. Again I^2R and eddy current losses are reduced.
3. Many HMT designs are highly efficient at 60Hz as well as at harmonic frequencies. Energy Star compliant models meet NEMA TP-1 energy efficiency minimums at 35% loading. This is typically achieved by reducing core losses to further improve efficiencies under lightly loaded conditions. For optimum energy efficiency performance, Mirus' Energy Star compliant Harmony™ Series HMT's are designed to meet NEMA TP-1 minimum efficiencies not only at 35% but in the entire operating range from 35% to 65%.

Figure 14-1 provides an example of the energy savings that can be realized when HMT's are used in lieu of conventional or K-rated transformers. A K-9 load profile, typical of a high concentration of computer equipment (I_{thd} = 83%), was selected for the analysis. Losses were calculated for various types of 75 kVA transformers at varying load conditions. In the graph, Conv is a conventional delta-wye transformer, K-13 is a K-13 rated delta-wye and H1E is a Harmony-1E™ single output Energy Star compliant HMT.

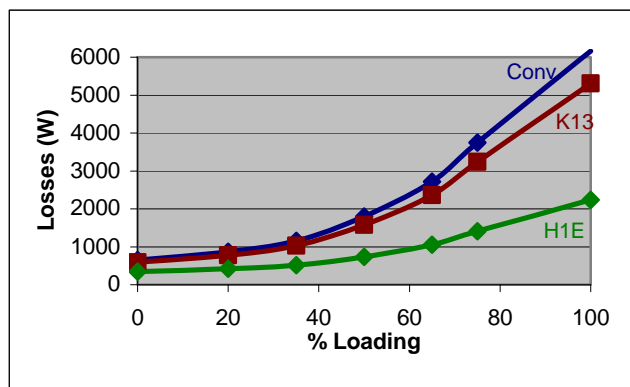

Figure 14-1: 75 kVA Transformer losses at various loading conditions with non-linear K-9 load profile.

The chart shows how energy savings become more and more substantial as a transformer's load increases. This is logical since it is the load losses which are most affected by the harmonic currents and these are proportional to the square of the current (I^2R and I^2h^2).

Figure 14-2 further emphasizes how transformer efficiencies are affected by non-linear loading. It compares the performance of various types of transformers with linear loading (K-1) and non-linear loading (K-9). The efficiencies of the conventional and K-13 transformer are much lower when they are subjected to a load with a K-9 profile, especially under the heavier loading conditions.

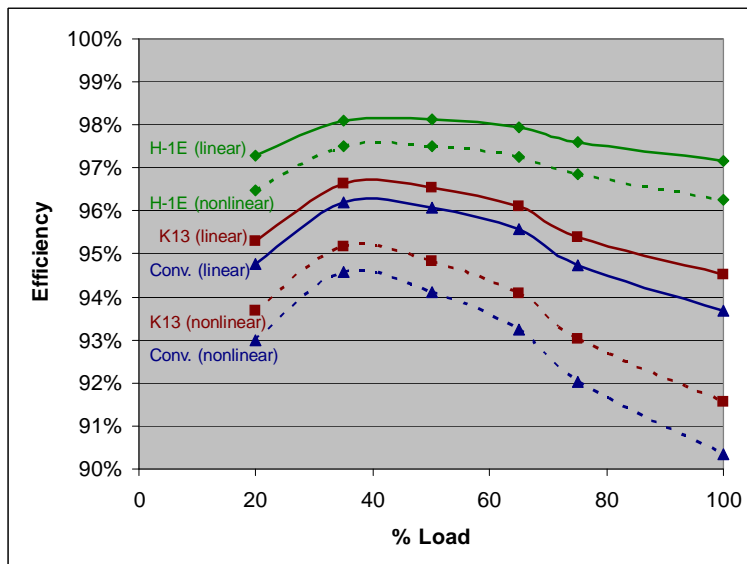

Figure 14-2: Energy Efficiencies for various types of 75 kVA transformers supplying linear (K-1) loads and non-linear (K-9) loads under varying load conditions.

Determining the amount of energy savings associated with a reduction in harmonic losses requires information on the Electric Utility rate and the load's operating profile. These parameters can vary quite substantially depending upon the location of the facility and the specific application. Table 14-1 shows the energy savings that can be realized when a Harmony-1E HMT is compared with a typical K-13 transformer. As in the previous examples, the transformers are 75 kVA and the non-linear load profile is that of a typical K-9 load.

Transformer	% Load	Losses (Watts)			Annual Consumption		Transformer Cost (Est.)	Payback on HMT Premium
		NLL	LL	Total	(kWhrs)	(\$ / yr)		
K-13	35%	590	411	1001	3,866	\$365	\$2,750	
	50%	590	928	1518	5,478	\$518		
	65%	590	1668	2258	7,787	\$736		
	100%	590	4445	5035	16,453	\$1,555		
Harmony-1E	35%	345	165	510	2,025	\$191	\$3,530	4.5 yrs
	50%	345	373	718	2,674	\$253		2.9 yrs
	65%	345	671	1016	3,606	\$341		2.0 yrs
	100%	345	1794	2139	7,109	\$672		0.9 yrs

Table 14-1: HMT energy savings and payback estimate comparing a 75 kVA HMT to a K-13 transformer in a typical office environment with a high concentration of computer equipment

The monetary savings are based on the equipment operating 12 hours per day, 260 days per year at an average Utility rate of \$0.07 per kWhr and assumes that additional cooling energy is required by the building's air conditioning system to remove the heat produced by the transformer losses. The calculation is as follows:

$$Annual\ Consumption = (Total\ losses\ in\ kW) \times (hrs/day) \times (days/yr) + (NL\ loss\ in\ kW) \times (24 - hrs/day) \times (365 - days/yr)$$

$$$/yr\ Savings = (HIE\ Annual\ Consumption - K13\ Annual\ Consumption) \times 1.35 \times (rate\ in\ $/kWhr)$$

This previous example could be typical of an office environment with a high concentration of computer loads and with the transformer located in air conditioned space. The requirement to cool the heat produced by the transformer's losses is typically 30% to 40% of the power in the losses (thus the 1.35 multiplier in calculation of \$/yr Savings). Paybacks were calculated based on estimated transformer costs and would result in recovering the Harmony-1E premium many times over based on the transformer's life expectancy of 30 to 40 years.

Table 14.2 provides another example. In this case, a lower harmonic content K4 load profile was used with the equipment operating 24 hrs/day, 365 days a year and the transformer located in air conditioned space. An example of such a location might be a Broadcasting Facility or Data Center. As can be seen, paybacks are even more attractive.

Transformer	% Load	Losses (Watts)			Annual Consumption		Transformer Cost (Est.)	Payback on HMT Premium
		NLL	LL	Total	(kWhrs)	(\$ / yr)		
K-13	35%	590	367	957	8,381	\$792	\$2,750	
	50%	590	835	1425	12,482	\$1,180		
	65%	590	1508	2098	18,381	\$1,737		
	100%	590	4054	4644	40,681	\$3,844		
Harmony-1E	35%	345	164	509	4,458	\$421	\$3,530	2.1 yrs
	50%	345	374	719	6,302	\$596		1.3 yrs
	65%	345	678	1023	8,958	\$847		0.9 yrs
	100%	345	1827	2172	19,024	\$1,798		0.4 yrs

Table 14-2: HMT energy savings and payback estimate comparing a 75 kVA HMT to a K-13 transformer in a typical Broadcasting Facility or Data Center

In summary, the inherent ability of Harmonic Mitigating Transformers to cancel harmonic currents within their windings can result in quantifiable energy savings when compared with the losses that would exist if conventional or K-rated transformers were used. If we consider the average premium cost of an HMT over a K-13 transformer, the typical payback in energy savings is 1 to 4 years when loading is expected to be in the 50% to 65% range.

[<Back to Questions>](#)

15. What constitutes an EPA Energy Star Transformer and is it important when supplying non-linear loads?

The Energy Star program is sponsored by the US Environmental Protection Agency (EPA) and is designed to encourage the use of energy efficient products. The Energy Star logo is found on many household appliances and other products identifying that they've been designed to specific energy efficiency standards.

For transformers, the Energy Star program is based upon the NEMA TP-1 'Guide for Determining Energy Efficiency for Distribution Transformers'. NEMA TP-1 defines minimum efficiency levels for transformers with linear loads at 35% loading. This criteria was chosen based on surveys which indicated that the average loading on distribution transformers in North America is about 35%. The efficiency limits vary by transformer size but are generally in the 98% range. In choosing 35% loading, NEMA TP-1 puts extra emphasis on no-load (core) losses rather than load (copper) losses. Because of its emphasis on no-load losses, NEMA TP-1 specifically exempts transformers which service non-linear loads. The following are taken from its exemption list:

- c. Drives transformers, both AC and DC
- d. All rectifier transformers and transformers designed for high harmonics
- g. Special impedance, regulation and harmonic transformers

The reason that transformers designed for high harmonics are exempted is that harmonics will dramatically increase load losses (I^2R and eddy current) and have very little effect on no-load losses. Therefore, NEMA TP-1's emphasis on no-load losses can be counter productive when supplying non-linear loads. To meet the efficiency limits, a manufacturer must optimize for lower no-load losses, sometimes at the expense of higher load losses. For example, one common way of reducing no-load losses is to add more steel to the transformer's core. With a larger core, each turn of the transformer's windings must cover a larger circumference. The extra length of copper winding adds resistance which increases I^2R load losses. This can significantly INCREASE losses and REDUCE efficiencies when supplying non-linear loads at load levels above 50%.

For an optimal HMT energy efficiency design, Mirus' Harmony-1E™ HMT not only meets NEMA TP-1 minimum efficiencies at 35% load but also in the entire operating range from 35% to 65%. In this manner, we can assure energy savings not only at lightly loaded conditions but also at more heavily loaded conditions when harmonics have their most significant influence on losses. (See Figures 14-1 and 14-2 in Question 14 for comparison of energy savings).

[<Back to Questions>](#)**16. How reliable are transformer energy efficiency tests (including Independent 3rd Party) under non-linear loading?**

It is much more difficult to accurately determine the energy efficiency of a transformer under non-linear loading than it is under linear loading. The industry accepted technique for measuring transformer efficiency under linear load involves measuring losses using Open Circuit and Short Circuit Tests. The Open Circuit or No-load Test measures core losses (iron losses). The Short Circuit Test or Load Test measures load losses which are also called I^2R losses or copper losses. This allows for calculation of Transformer Efficiency = Output Power / (Output Power + Total Losses). This calculation is equivalent to Efficiency = Output Power / Input Power but produces more accurate and repeatable results.

The example below shows how very accurate efficiency calculations can be achieved by measuring losses directly even with a relatively inaccurate power meter (+/- 1.0%).

True Output Power = 97 kW
 True Input Power = 100 kW, Losses = 3 kW
 True Efficiency = 97 / 100 or 97%.

Measuring losses directly with a +/- 1.0% power meter yields a measurement error of only +/- 0.03% as follows:

Output Power = 97kW
 Measured Losses = 3kW - (0.01 x 3 kW) = 2.97 kW
 Efficiency = 97 / (97 + 2.97) = 97 / 99.97 = 97.03%

Unfortunately this method of directly measuring the losses themselves inherently applies only to transformer operation with a linear load. For non-linear load we must revert to a much less accurate method of calculating efficiency based upon direct measurements of Output and Input Power. This method will only produce acceptable results if measurements are taken simultaneously by two highly accurate power meters.

An example of how output power vs input power measurements using meters of average measurement accuracy (ie. +/- 0.5%) can produce misleading results is shown below. The earlier example is used but this time measuring input and output power with a meter of +/- 0.5% accuracy (better than previous +/- 1.0%).

Measured Output Power = 97kW + 0.5kW = 97.5 kW
 Measured Input Power = 100kW - 0.5kW = 99.5kW
 Calculated Efficiency = 97.5 / 99.5 = 98%, a full 1% error despite measurement accuracy within +/- 0.5%.

This results in a reported 98% efficiency for a transformer that is truly only 97%. Similarly, the calculated result could have been 96% if the errors were reversed. To emphasize the significance of this error, reporting 98% on a transformer that is actually 97% means losses are under reported by a full 1/3 (ie. 2% losses instead of 3%). The measurements are essentially useless. This inaccuracy is magnified further if only one meter is used because even a very small change in the load power between measurements will very dramatically affect the results.

To provide truly accurate and reliable transformer efficiency measurements under non-linear loading, Mirus has built a Non-linear Load Test facility, known as the Harmonics & Energy or H&E Lab, at its manufacturing facility near Toronto (see Figure 16-1).

The H&E Non-linear Load Bank has the capability of loading transformers up to 225 kVA to their full load rating. Larger transformers can be loaded proportionately (ie. 500 kVA to 45% load). This is believed to be the largest 120V phase-to-neutral non-linear load bank of any transformer manufacturer, including all other HMT manufacturers.

In order to achieve the most accurate measurements possible, the H&E Lab is equipped with two revenue class digital power meters with an accuracy of 0.1% and current transformers with 0.3%



Figure 16-1: H&E Lab showing Non-linear Load Bank

accuracy. The meters can measure up to the 63rd harmonic. One meter is used to connect to the transformer primary while the second meter is connected to the transformer secondary. To further improve measurement accuracy, efficiency calculations are based on kW-sec totalization rather than on instantaneous kW readings in order to minimize any sample timing error.

The Non-linear Load Bank in the H&E Lab consists of several Variable Frequency Drives fed with 1-phase power. When supplied with 1-phase power, the 3-phase diode bridge rectifier of a VFD draws current which has a waveform and harmonic spectrum that is representative of a very high K-factor, 1-phase non-linear load similar to that of computer power supplies and other power electronic equipment connected phase-to-neutral.



Figure 16-2: Metering Console equipped with 2 x PML ION 7500 Digital Meters

A sample of the typical load profile of the Non-linear Load Bank is shown in Figure 16-3. In this example, a 45 kVA transformer was operated at both 100% and 50% loading. At full load, secondary current was 129A with a K-factor of just over 9 and current total harmonic distortion (Ithd) of 81%. At 50% load, the K-factor increased to over 13 with Ithd > 90%.

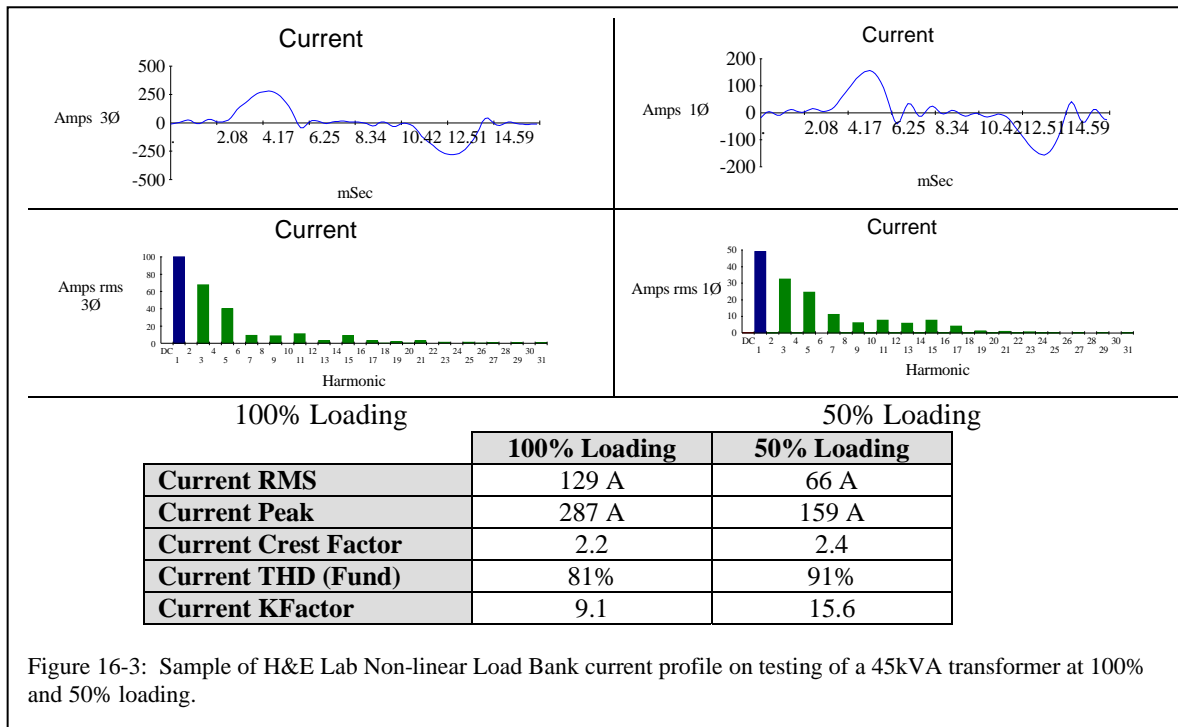

In summary, claims of highly accurate transformer testing under non-linear loading by any party should not be accepted without reviewing their complete test procedure and full test report including documentation on measurement techniques and certified instrumentation accuracy. This is particularly important if testing was performed with a single power meter because it would be impossible to take measurements simultaneously..

[<Back to Questions>](#)**17. Am I not safe from harmonics if I use K-Rated transformers and oversized neutrals?**

K-Rated transformers made their appearance several years ago as a means of preventing transformers from failing when subjected to heavy non-linear loading. They are essentially 'beefed up' transformers with extra steel in their cores and copper in their windings to allow for better dissipation of the excessive losses produced by harmonic currents. They are not designed to cancel harmonics or their fluxes and therefore, do nothing but protect themselves from overheating. Harmonic losses are normally not significantly reduced and voltage distortion will typically remain quite high under more heavily loaded conditions. To improve power quality in the form of reduced voltage distortion and to save energy costs, the use of a transformer designed to cancel harmonics is necessary.

Over-sizing neutrals, on the other hand, can be a reasonably low cost method for the prevention of neutral conductor overheating. It is important to remember that the non-linear loads are the source of the harmonic currents. They must flow from the loads back to the transformer. Because the 3rd and 9th current harmonics created by the 120 VAC switch-mode power supplies are flowing back on the neutral, the neutral current is usually larger than the phase currents (see Question 7). This is of minimal consequence provided the neutral has suitable ampacity to carry the extra current and the 120/208V 4-wire run length is not too long.

A point of caution. When selecting phase and neutral conductor sizes in a non-linear load application, the electrical code requires that an ampacity adjustment or correction factor be applied. This is because the neutral conductor is considered to be a current carrying conductor along with PhA, PhB and PhC. With more than 3 current carrying conductors in a conduit or raceway, a 0.8 factor must be applied.

To minimize harmonic problems in new installations, avoid the old approach of using a large central transformer with a 120/208V secondary and long 4-wire risers or radial runs through the building. The impedances of these long runs are high so that harmonic currents flowing through these impedances will create high levels of voltage distortion and neutral-to-ground voltage. To prevent these problems, an effective rule of thumb is to limit each 120/208V run length to that which would produce a 60Hz voltage drop not greater than 1/2% to 3/4%. For a typical 200 amp feeder this would be < 50 ft.

Combining the use of Harmonic Mitigating Transformers with short 120/208V feeder runs and double ampacity neutrals will ensure compatibility between the distribution system and the non-linear loads. Generally this will keep voltage distortion safely below the maximum of 5% as recommended for sensitive loads in IEEE Std 519-1992.

[<Back to Questions>](#)

18. Are there standards that can help in addressing harmonics?

The standard most commonly applied to the control of harmonics in Power Systems is IEEE standard 519, 'IEEE Recommended Practices and Requirements for Harmonic Control in Electrical Power Systems'. This standard recommends maximum acceptable limits for both voltage and current harmonics to prevent problems that can result from heavy non-linear loading. The limits for harmonic currents are designed to minimize the amount of voltage distortion these currents would produce in the power system.

[<Back to Questions>](#)**19. Can neutral currents, such as the 3rd harmonic, be reduced by the use of 3rd harmonic blocking filters?**

Some manufacturers are promoting the use of 3rd harmonic (180 Hz) blocking filters for the treatment of high neutral currents caused by non-linear loads such as personal computers. These devices are parallel L-C filters tuned to 180 Hz and are connected in the neutral of 4-wire systems between the transformer secondary and the neutral-to-ground connection. Their high impedance to the flow of 3rd harmonic current forces all connected equipment to draw current that does not contain the 3rd harmonic. Although their use will result in a significant reduction in 3rd harmonic current, it is achieved at the risk of rather severe consequences.

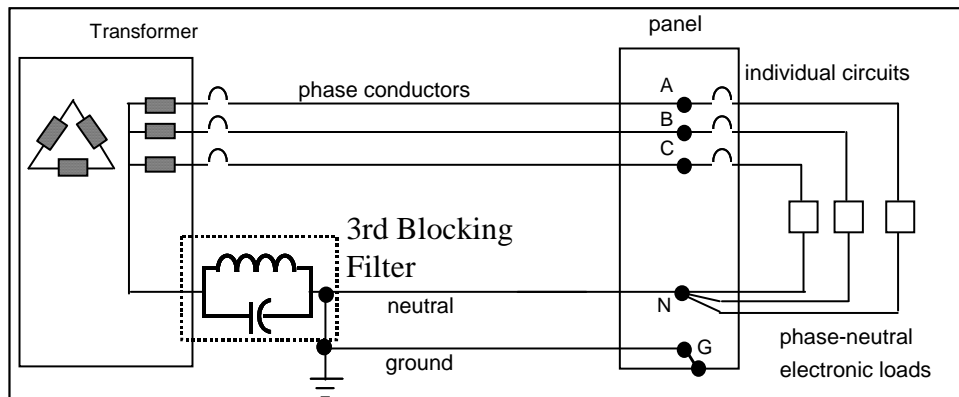

Figure 14: Typical installation of 3rd Harmonic Blocking Filter

Some reasons for concern are as follows:

1. The installation raises questions with respect to *NEC 2002* compliance. *NEC 250.30(A)(2)(a)* states that “a grounding electrode conductor for a single separately derived system ... shall be used to connect the grounded conductor of the derived system to the grounding electrode...” In addition, “the grounding electrode conductor shall be installed in one *continuous* length without a splice or joint...” [italics added. See *NEC 250.64(C)*]. If a simple splice connection is not allowed, then certainly the L-C circuit of the 3rd harmonic blocking filter should not be allowed either. Also, the installation results in an impedance grounded wye system rather than a solidly grounded system. The only reference in *NEC* that allows for the introduction of an impedance between the neutral and the grounding electrode is found in Section 250.36, High-Impedance Grounded Neutral Systems. However, these systems are permitted only at 480V and higher and only if they do not serve line-to-neutral loads. They also require the use of ground fault detectors. None of these requirements is met in the normal application of the 3rd harmonic blocking filter where the loads are primarily 120V, phase-to-neutral connected computer or other power electronic equipment.
2. Although tuned to 180 Hz, the L-C circuit will introduce some impedance at 60 Hz as well. The consequences are:
 - a. Line-neutral short circuit current will be reduced which will limit a circuit breakers ability to clear a line-neutral fault. This can be very dangerous because an uninterrupted fault (commonly referred to as an arcing fault) will often result in an electrical fire.
 - b. The neutral point at the transformers wye secondary can shift. This can result in 120V line-neutral voltages that rise and fall unpredictably as the load balance between the phases varies.
3. High impedance to the flow of 3rd harmonic current will produce voltage distortion in the form of flat-topping - a dramatic reduction in peak to peak voltage. This will:
 - a. Significantly reduce the ride-through capability of switch-mode power supplies (SMPS) since the DC smoothing capacitors will not be allowed to fully charge.
 - b. Reduce the SMPS DC bus voltage, thereby increasing the current demand and the associated I^2R losses. Component reliability will be reduced due to higher operating temperatures.
 - c. Often cause 1-ph UPS systems to switch to battery back-up.
 - d. Force connected equipment to operate without 3rd harmonic current – an operating mode for which they have not been intended or tested.

[<Back to Questions>](#)

At first, when loading is light, problems may not be extremely obvious. However, as the load increases, voltage distortion and flat-topping will also increase until problems do arise. Figure 2 shows the voltage waveform of a 3rd Harmonic Blocking Filter installation at a financial institution. Although neutral current was indeed reduced, it was achieved at the expense of a tremendous increase in voltage distortion. At 30%, the voltage distortion was 6 times the maximum limit of 5% recommended by IEEE std 519. In addition, the crest factor of 1.19 was 19% below the normal sinusoidal crest factor of 1.414. (For an explanation of the effect of voltage flat-topping on connected equipment, see Question 9).

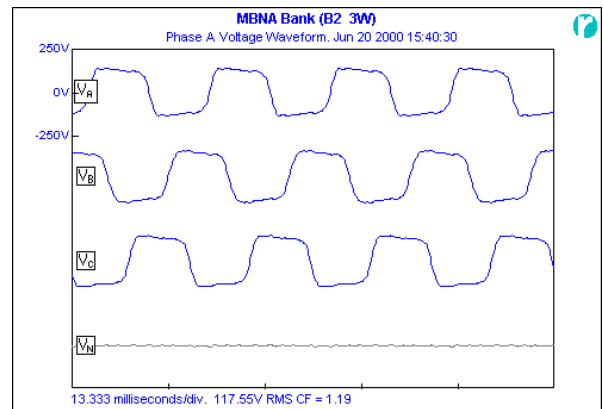

Figure 2: Voltage Flat-topping caused by 3rd Harmonic Blocking Filter

4. The 180 Hz L-C blocking filter requires the use of capacitors and it is well known that capacitors are less reliable than inductors and transformers. Failure of the capacitor or its protection could result in a very high impedance ground at the neutral over the full frequency range. This would have a dramatic effect on 60 Hz unbalance and fault currents.
5. At frequencies above the resonant point (180 Hz), the parallel L-C circuit becomes capacitive which could result in a resonant condition at some higher harmonic frequency.

A much better strategy for 3rd harmonic current treatment is the use of a parallel connected low zero sequence impedance filter such as the MIRUS Neutral Current Eliminator™ (NCE™). This device provides a lower impedance, alternate path for the flow of 3rd harmonic and other zero sequence currents, thereby off-loading the neutral conductor and upstream transformer. In addition, voltage distortion is decreased because the harmonic currents no longer pass through the transformer and cable impedance. For more information on the zero sequence filter, see Question 11.

References:

1. A. Hoevenaars, *3rd Harmonic Blocking Filters – Is the Cure Worse than the Disease*, IAEI News, Sept/Oct 2002, pp. 68 - 74



LINEATOR™ Advanced Universal Harmonic Filter for VFD's Questions and Answers

This document has been written to provide answers to the more frequently asked questions we have received regarding the application of the LINEATOR™ Advanced Universal Harmonic Filter on Variable Frequency Drives (VFD's). This information will be of interest to both those experienced in treatment of harmonics generated by VFD's and those new to the problem of harmonics. For additional information visit our Website at <http://www.mirusinternational.com>.

1. [What are non-linear loads and why are they a concern today?](#)
2. [Do different types of non-linear loads generate different harmonics?](#)
3. [Why do non-linear loads have low power factors and why is it important to have a high power factor?](#)
4. [What is a Variable Frequency Drive and how does it generate harmonics?](#)
5. [What problems do non-linear loads and harmonics create?](#)
6. [How do non-linear loads create current and voltage harmonics?](#)
7. [What ill effects do the harmonics created by VFD's have on themselves?](#)
8. [What is IEEE Std 519 and how does it apply to VFD installations?](#)
9. [What is the LINEATOR™ AUHF and how does it treat VFD harmonics?](#)
10. [How is the LINEATOR™ different than other forms of passive harmonic filters?](#)
11. [What other forms of harmonic treatment are available for VFD's?](#)
12. [How does the LINEATOR™ compare to a 12-Pulse or 18-Pulse VFD?](#)
13. [Is the LINEATOR™ compatible with all VFD's?](#)
14. [Is the LINEATOR™ suitable for generator applications?](#)
15. [What if my VFD is equipped with a by-pass?](#)
16. [Can I use a single LINEATOR to supply multiple VFD's?](#)
17. [Can I get a computer simulation to demonstrate compliance with IEEE Std 519 or simply to show the LINEATOR™'s effectiveness in a specific application?](#)
18. [What kind of performance guarantee does the LINEATOR™ have?](#)
19. [What information is required to properly apply the LINEATOR™ AUHF?](#)

[<Back to Questions>](#)

1. What are non-linear loads and why are they a concern today?

A load is considered non-linear if its impedance changes with the applied voltage. The changing impedance means that the current drawn by the non-linear load will not be sinusoidal even when it is connected to a sinusoidal voltage. These non-sinusoidal currents contain harmonic currents that interact with the impedance of the power distribution system to create voltage distortion that can affect both the distribution system equipment and the loads connected to it.

In the past, non-linear loads were primarily found in heavy industrial applications such as arc furnaces, large variable speed drives, heavy rectifiers for electrolytic refining, etc. The harmonics they generated were typically localized and often addressed by knowledgeable experts.

Times have changed. Harmonic problems are now common in not only industrial applications but in commercial buildings as well. This is due primarily to new power conversion technologies, such as the Switch-mode Power Supply (SMPS), which can be found in virtually every power electronic device (computers, servers, monitors, printers, photocopiers, telecom systems, broadcasting equipment, banking machines, etc.). Another major influence is the more widespread use of variable frequency drives in commercial HVAC applications (chillers and fans) and industrial pumping (oil and gas, water/waste water, etc.). Their proliferation has made non-linear loads a substantial portion of the total load in most commercial buildings as well as industrial facilities.

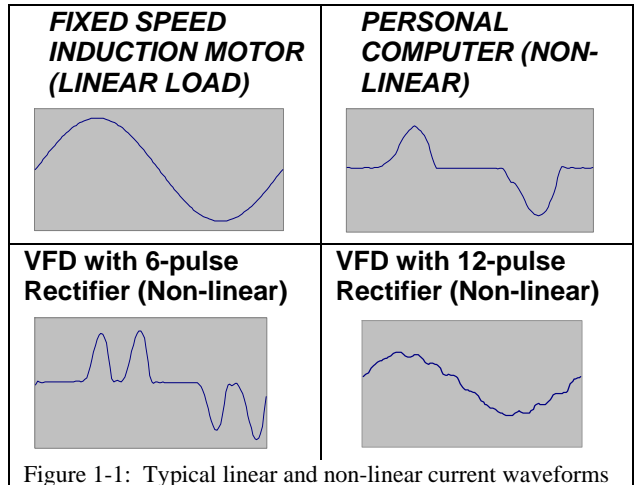

Figure 1-1: Typical linear and non-linear current waveforms

Examples of the current drawn by various types of equipment are shown in Figure 1-1. The most common form of distorted current is a pulse waveform with a high crest factor. The VFD is one such load since it consists of a 6-pulse rectifier bridge (to convert AC to DC) and a large filter capacitor on its DC bus. The VFD draws current in short, high-amplitude pulses that occur right at the positive and negative peaks of the 3-phase supply voltage. Typically these high current pulses will cause clipping or flat-topping of the voltage waveform. Further discussions on voltage flat-topping and its effect on connected equipment can be found in answers to Questions 6 and 7.

[<Back to Questions>](#)

2. Do different types of non-linear loads generate different harmonics?

By far the majority of today’s non-linear loads are rectifiers with DC smoothing capacitors. These rectifiers typically come in 3 types – (i) single phase, line-to-neutral, (ii) single phase, phase-to-phase and (iii) three-phase.

Single-phase line-to-neutral rectifier loads, such as switch-mode power supplies in computer equipment, generate current harmonics 3rd, 5th, 7th, 9th and higher. The 3rd will be the most predominant and typically the most troublesome. 3rd, 9th and other odd multiples of the 3rd harmonic are often referred to as triplen harmonics and because they add arithmetically in the neutral are also considered zero sequence currents. Line-to-neutral non-linear loads can be found in computer data centers, telecom rooms, broadcasting studios, schools, financial institutions, etc.

208V single-phase rectifier loads can also produce 3rd, 5th, 7th, 9th and higher harmonic currents but if they are reasonably balanced across the 3 phases, the amplitude of 3rd and 9th will be small. Because they are connected line-line, these loads cannot contribute to the neutral current. The largest current and voltage harmonics will generally be the 5th followed by the 7th. Typical single phase, 208V rectifier loads include the switch-mode power supplies in computer equipment and peripherals.

Three-phase rectifier loads are inherently balanced and therefore generally produce very little 3rd and 9th harmonic currents unless their voltage supply is unbalanced. Their principle harmonics are the 5th and 7th with 11th and 13th also present. They cannot produce neutral current because they are not connected to the neutral conductor. The rectifiers of variable speed drives and Uninterruptible Power Supplies (UPS) are typical examples of three-phase rectifier loads.

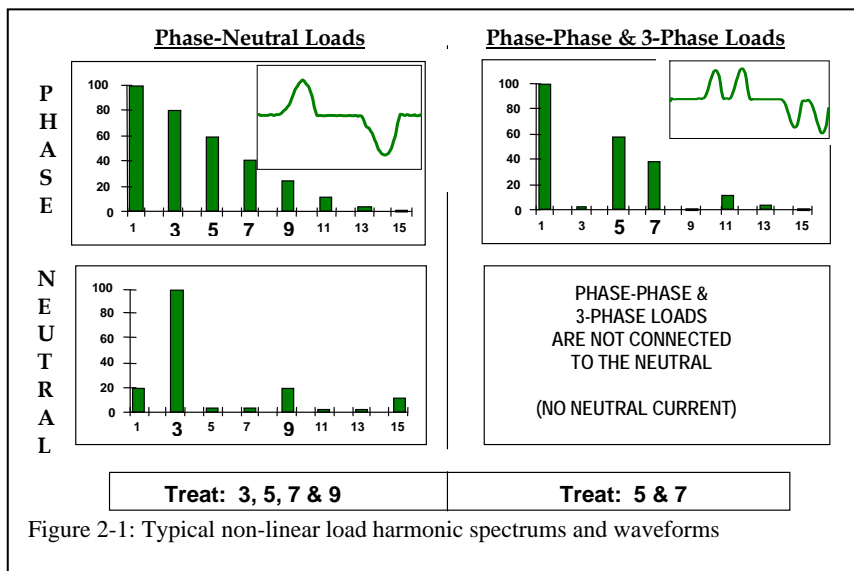

Figure 2-1: Typical non-linear load harmonic spectrums and waveforms

[<Back to Questions>](#)

3. Why do non-linear loads have low power factors and why is it important to have a high power factor?

Power factor is a measure of how effectively a specific load consumes electricity to produce work. The higher the power factor, the more work produced for a given voltage and current. Figure 3-1 shows the power vector relationships for both linear and non-linear loads. Power factor is always measured as the ratio between real power in kilowatts (kW) and apparent power in kilovoltamperes (kVA).

For linear loads, the apparent power in kVA ($S = V \cdot I$) is the vector sum of the reactive power in kVAR (Q) and the real power in kW (P). The power factor is $P/S = \cos\Phi$, where Φ is the angle between S and P. This angle is the same as the displacement angle between the voltage and the current for linear loads. For a given amount of current, increasing the displacement angle will increase Q, decrease P, and lower the PF. Inductive loads such as induction motors cause their current to lag the voltage, capacitors cause their current to lead the voltage, and purely resistive loads draw their current in-phase with the voltage. For circuits with strictly linear loads (a rare situation) simple capacitor banks may be added to the system to improve a lagging power factor due to induction motors or other lagging loads.

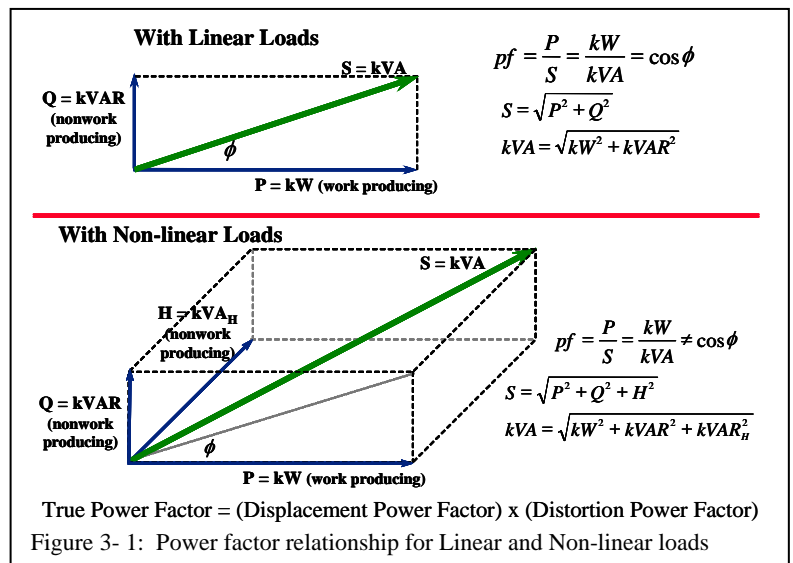

Figure 3- 1: Power factor relationship for Linear and Non-linear loads

For non-linear loads, the harmonic currents they draw produce no useful work and therefore are reactive in nature. The power vector relationship becomes 3 dimensional with distortion reactive power, H, combining with both Q and P to produce the apparent power which the power system must deliver. Power factor remains the ratio of kW to kVA but the kVA now has a harmonic component as well. True power factor becomes the combination of displacement power factor and distortion power factor. For most typical non-linear loads, the displacement power factor will be near unity. True power factor however, is normally very low because of the distortion component. For example, the displacement power factor of a 6-Pulse VFD without a reactor will be near unity but its total power factor is often in the 0.65 – 0.7 range. The best way to improve a poor power factor caused by non-linear loads is to remove the harmonic currents.

Most Utilities charge their customers for energy supplied in kilowatt-hours during the billing period plus a demand charge for that period. The demand charge is based upon the peak load during the period. The demand charge is applied by the utility because it must provide equipment large enough for the peak load even though the customer's average power may be much lower. If the power factor during the peak period (usually a 10 minute sliding window) is lower than required by the utility (usually 0.9 or 0.95), the utility may also apply a low PF penalty charge as part of the demand charge portion of the bill.

Suppose the peak demand was 800kW with apparent power consumption of 1000kVA (a PF of 0.8). If a power factor penalty was applied at 0.9, the utility would charge the customer as if his demand was 0.9 x 1000kVA = 900kW even though his peak was really 800kW, a penalty of 100kW. Improving the power factor to 0.85 at 1000kVA demand would lower the penalty to just 50kW. For power factors of 0.9 to 1.0, there would be no penalty and the demand charge would be based upon the actual peak kW. The demand charge is often a substantial part of the customer's overall power bill, so it is worthwhile to maintain good power factor during peak loading and reducing the harmonic current as drawn by the loads can help achieve this.

References:

1. Roger C. Dugan, *Electrical Power Systems Quality*, McGraw-Hill, New York NY, 1996, pp. 130-133
2. H. Rissik, *The Fundamental Theory of Arc Convertors*, Chapman and Hall, London, 1939, pp 85-97

[<Back to Questions>](#)

4. What is a Variable Frequency Drive and how does it generate harmonics?

A Variable Frequency Drive (VFD) is a solid state device that converts utility power to a variable voltage and frequency in order to control the speed of a 3-phase induction motor. By controlling the motor's speed, both energy savings and better motor control can be achieved.

Figure 4.1 shows a typical VFD schematic diagram. The front-end rectifier and its DC bus smoothing capacitors make the VFD a non-linear load since it will draw current in a non-sinusoidal manner.

The characteristic harmonics generated by a diode bridge rectifier will follow the relationship below:

$$h = np \pm 1, \text{ where: } h = \text{the harmonic number}$$

$$n = \text{any integer}$$

$$p = \text{the pulse number of the rectifier}$$

Most VFD's use a 3-phase, 6-pulse ($p = 6$) rectifier which results in currents of harmonic number 5, 7, 11, 13, 17, 19, etc. being generated. When dual rectifiers are used and phase shifted by 30° a 12-pulse scheme is created. 12-pulse VFD's will only have residual amounts of 5th and 7th harmonics since substituting $p = 12$ in the above equation results in harmonics 11, 13, 23, 25, etc. Other multipulse schemes such as 18 and 24 can be used to reduce harmonics further.

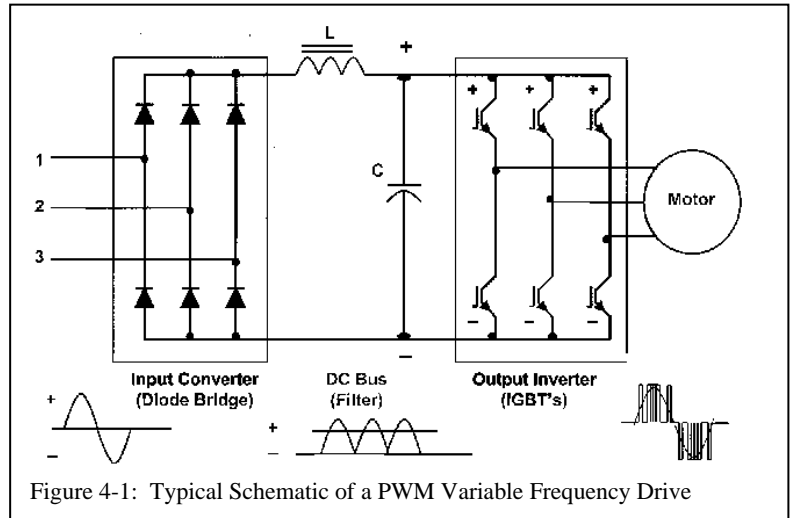

Figure 4-1: Typical Schematic of a PWM Variable Frequency Drive

5. What problems do non-linear loads and harmonics create?

Most power systems can accommodate a certain level of harmonic currents but will experience problems when they become a significant component of the overall load. As these higher frequency harmonic currents flow through the power system, they can create problems such as:

- Overheating of electrical distribution equipment, such as cables, transformers, standby generators, etc.
- Overheating of rotating equipment, such as electric motors
- High voltages and circulating currents caused by harmonic resonance
- Equipment malfunctions due to excessive voltage distortion
- Increased internal losses in connected equipment resulting in component failure and shortened lifespan
- False operation of protection equipment
- Metering errors
- Lower system power factor preventing effective utilization
- Voltage regulator problems on diesel generators
- Inability of automatic transfer switches to operate in closed transition

Harmonics overheat equipment by several means. For example, in electric machines and transformers, harmonic currents cause additional power losses by (i) increasing the eddy currents that flow in their laminated cores, (ii) through increased leakage currents across insulation and (iii) by producing skin effect in conductors

The fact that harmonic currents create voltage distortion as they flow through the power system's impedance makes their impact even more serious. It is voltage distortion, not current distortion, that will affect the connected equipment on the power system. For more on how non-linear loads create voltage distortion and how this can affect connected equipment, see Questions 6.

[<Back to Questions>](#)

6. How do non-linear loads create current and voltage harmonics?

The front-end rectifier of a VFD is an excellent example of a non-linear load. Because it draws current in non-sinusoidal pulses, the VFD is a significant generator of harmonic currents. When found in high densities VFD's can be a major contributor to voltage distortion. The pulsed current of a 3-phase diode bridge rectifier will produce voltage distortion in the form of flat-topping. Since current is consumed only at the peak of the voltage waveform (to charge the smoothing capacitor), voltage drop due to system impedance will also occur only at the peak of the voltage waveform. A flattened voltage peak will reduce the DC bus voltage of the VFD, reduce its power disturbance ride-through capability, and increase both its current draw and I²R losses.

Another way to analyze the operation of the system with non-linear loads is to calculate the effect of each individual harmonic current as it flows through the various impedances of the distribution system. Fourier analysis tells us that the 6-pulse current drawn by the VFD's rectifier has a fundamental frequency component plus odd harmonics which include the 5th, 7th, 11th and 13th. When modeling the distribution system, we can think of each VFD as a generator of harmonic currents. Each harmonic current injected into the power system by a non-linear load will flow through the system impedance, resulting in a voltage drop at that harmonic frequency. The amount of voltage drop follows Ohm's Law (V_h = I_h x Z_h) where:

- V_h = voltage at harmonic number h
- I_h = amplitude of current harmonic h
- Z_h = impedance of the system to harmonic h.

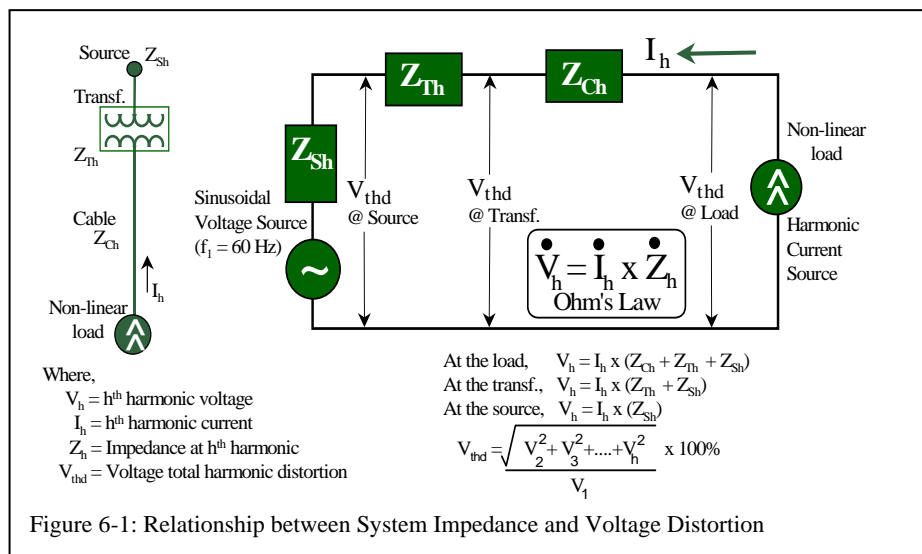

Figure 6-1 shows the relationship between system impedance and the voltage and current distortion components at several points in a typical power system.

We can calculate the RMS value of the voltage or current distortion if we know the RMS values of all of the components. Parseval's Theorem tells us that the RMS value of a waveform is equal to the square root of the sum of the squares of the RMS values of the fundamental component and all of the harmonic components of the waveform.

The fundamental is not a distortion component, so the RMS value of the distortion is just the square root of the sum of the squares of the harmonic components. Usually this is expressed as percentage of the value of the fundamental component and is called the *Total Harmonic Distortion*, or *THD*.

Voltage total harmonic distortion (V_{thd}) is calculated as:

$$V_{thd} = \frac{\sqrt{V_2^2 + V_3^2 + V_4^2 + V_5^2 + \dots}}{V_1} \times 100\%$$

Similarly, current total harmonic distortion is calculated as:

$$I_{thd} = \frac{\sqrt{I_2^2 + I_3^2 + I_4^2 + I_5^2 + \dots}}{I_1} \times 100\%$$

Voltage distortion then is a function of both the system impedance and the amount of harmonic current in the system. The higher the system impedance (ie. long cable runs, high impedance transformers, the use of diesel generators or other weak sources) the higher the voltage distortion.

In Figure 6-1, we see that voltage distortion is greatest at the loads themselves, since the harmonic currents are subjected to the full system impedance (cables, transformer and source) at that point. This is a characteristic most often misunderstood. It means that even if voltage distortion levels are low at the service entrance, they can be unacceptably high at the loads themselves. It also emphasizes the importance of keeping system impedances relatively low when servicing non-linear loads.

Voltage distortion can be minimized by removing the harmonic currents (I_h) and/or lowering the system impedance (Z_h) to the harmonics. (For further information on the relationship between voltage drop and voltage distortion and how to minimize them, we recommend two MIRUS technical papers titled (1) *'Taming the Rogue Wave – Techniques for Reducing Harmonic Distortion'* and (2) *'How the Harmonic Mitigating Transformer Outperforms the K-Rated Transformer'*).

7. What ill effects do harmonics created by VFD's have on themselves and the motor they supply?

Typical voltage distortion in the form of a severely flat-topped voltage waveform will translate to a lower DC bus voltage within the VFD. A lower DC voltage will prevent the inverter section of the VFD from generating a full rms AC voltage to the motor. When running near full load, a motor starved for voltage will draw more than its rated current, overheat and be prone to failure.

In addition, commutation notching/overvoltages caused by the operation of thyristor bridge rectifiers (or SCR's) in DC Drives or similar loads, have been known to cause AC Drive shutdowns and failures. Figure 7.1 shows voltage distortion on an off-shore oil platform with DC Drives. The severe voltage notching and overvoltages caused AC Drive failures until they were protected by LINEATOR™ AUHF's.

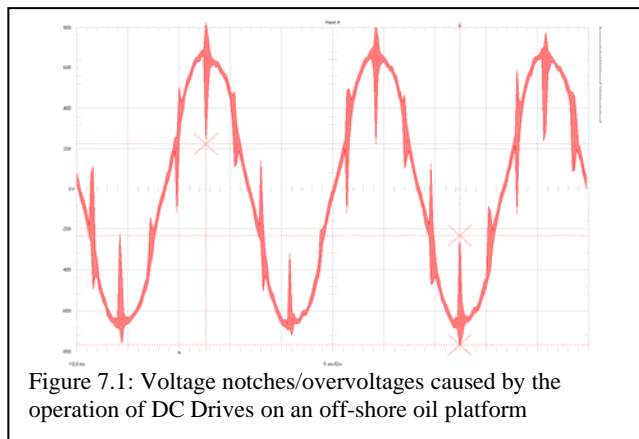

[<Back to Questions>](#)

8. What is IEEE Std 519 and how does it apply to VFD installations?

IEEE Std 519 was first introduced in 1981 as 'Recommended Practices and Requirements for Harmonic Control in Electrical Power Systems'. Most recently revised in 1992, it provides direction on dealing with harmonics introduced by static power converters and other nonlinear loads so that power quality problems can be averted. It is being applied by consulting engineers and enforced by Utilities more frequently in recent years as the use of Variable Frequency Drives and other non-linear loads has grown.

Although IEEE Std 519 can be useful for ensuring that VFD harmonics are controlled for trouble-free operation, it can be a somewhat difficult standard to apply. Two reasons for this are that it can be difficult to determine an appropriate point of common coupling (PCC) and to establish a demand current at the design stage. This is because the standard does not provide a very clear definition for PCC and the recommended definition of demand current is a value that can only be determined by measurements taken after installation. For one interpretation of how to apply IEEE Std 519 see the reference paper below.

In most VFD applications, it is difficult to meet the harmonic limits defined in IEEE Std 519 without some form of harmonic treatment. A minimum requirement is an AC line reactor or DC link choke but usually this simple form of treatment falls short of compliance. Often engineers will specify multipulse VFD's (typically 12 or 18-pulse) but these can be expensive, bulky and less efficient options. Combining a LINEATOR™ Advanced Universal Harmonic Filter with a standard 6-pulse VFD can be a very effective method of meeting IEEE Std 519 harmonic limits.

Reference:

1. A. Hoevenaars, K. LeDoux, M. Colosino, 'Interpreting IEEE Std 519 and Meeting Its Harmonic Limits in VFD Applications', PCIC-2003-15, PCIC 2003 Conference Proceedings, pp 145-150.

9. What is the LINEATOR™ AUHF and how does it treat VFD harmonics?

The LINEATOR™ a purely passive device consisting of a revolutionary new inductor combined with a relatively small capacitor bank. Its innovative design achieves cancellation of all the major harmonic currents generated by VFD's and other similar 3-phase, 6-pulse rectifier loads. By reducing current harmonic distortion to < 8% and often as low as 5%, the LINEATOR™ matches 18-Pulse VFD performance in a smaller footprint, at lower cost and with higher efficiency.

[<Back to Questions>](#)

10. How is the LINEATOR™ different from other forms of passive harmonic filters?

Although a truly passive filter, the LINEATOR™ exhibits none of the problems that plague conventional filters. The unique winding configuration of the LINEATOR™ reactor provides much better attenuation of harmonics than standard reactors thereby allowing the LINEATOR™ to get exceptional performance even with a much smaller capacitor bank than found in all other passive filters.

The large capacitor banks in both trap filters and broadband filters present a capacitive reactance to the system, especially under light loads. This can be a beneficial feature where inductive loads require a compensating reactance to improve a low displacement power factor. However, in many VFD applications, displacement power factor is quite high even though overall power factor is low due to the harmonic content. Compensation for inductive loads is not necessary and, in fact, can cause problems especially when the supply is an emergency standby generator. To address this, more sophisticated filters will be equipped with a mechanism for switching out the capacitors under light loads, increasing cost and complexity. Even under no load conditions, the capacitive reactance of the LINEATOR™ is so low that switching out the capacitors is unnecessary.

The conventional trap filter has no directional properties. It therefore, can easily be overloaded by attracting harmonics from upstream non-linear loads. The LINEATOR™, on the other hand, will present a high impedance to line side harmonics eliminating the possibility of inadvertent importation and overloading.

At frequencies below its tuned frequency, a conventional filter will appear capacitive. This capacitance has the potential of resonating with the power systems natural inductance. When a filter is tuned to a higher order harmonic, such as the 11th, it can easily resonate at a lower harmonic frequency, such as the 5th or 7th. The natural resonance frequency of the LINEATOR™ is below that of any predominant harmonic, therefore inadvertent resonance is avoided.

The filtering effectiveness of a trap filter is dependent upon the amount of harmonics present at untuned frequencies as well as the residual at the tuned frequency. To obtain performance better than 15% THID, multiple tuned branches are often required. Some broadband filters claim < 12% THID but require relatively large capacitor banks to achieve this. Even larger capacitors are required if further reduction in THID is desired. The LINEATOR™ will reduce current distortion to < 8% over the entire operating range and typically achieves near 5% THID at normal operating levels.

[<Back to Questions>](#)

11. What other forms of harmonic treatment are available for VFDs?

There are various methods presently available for treatment of VFD harmonics. Each has its advantages and disadvantages but none can achieve the price/performance level of the LINEATOR™.

Reactors and chokes are a relatively low cost solution but are only moderately effective and their high impedance can introduce trouble-some voltage drops.

Conventional tuned or trap filters, as their name implies, require tuning to a specific harmonic frequency. Their effectiveness is marginal unless multiple tuned elements are incorporated. Also, they are prone to problems such as resonance with other system components, importation of harmonics from upstream non-linear loads and a leading power factor.

By treating a wider spectrum of harmonics, broad-band filters are more effective than tuned filters but can also be more expensive. Although they address some of the issues associated with tuned filters, they are not trouble-free. Specifically, their large series inductor necessitates the use of a large capacitor bank to compensate for the voltage drop. These capacitors create a leading power factor which has been known to cause excitation control problems with generators.

	REACTOR	TUNED FILTER	LOW-PASS FILTER	MULTI PULSED	PHASE SHIFTING	ACTIVE FILTER	LINEATOR AUHF
Current Distortion	< 35%	< 15%	< 12%	< 12%	< 15%	< 5%	< 8%
Effective without Multiple Loads	Yes	Yes	Yes	Yes	No	Yes	Yes
Meets IEEE 519	Rarely	Maybe	Maybe	Maybe	Maybe	Yes	Yes
Attracting Upstream Harmonics	No	Yes	No	No	No	No	No
Engine Generator Compatibility	Partial	No	No	Yes	Yes	Yes	Yes
Inherent Transient Suppression	Yes	No	Yes	No	No	No	Yes
Efficiency	High	Moderate	Moderate	Moderate	Moderate to High	Low	High
Reduction in TIF Factor	Moderate	Moderate	High	Moderate	Moderate	High	High
Physical Size	Small	Large	Large	Very Large	Moderate to Large	Very Large	Moderate
Connection	Series	Parallel	Series	Series	Series	Parallel	Series
Price	Low	Moderate to High	High	High	Low to moderate	Very High	Moderate

Figure 11-1: Comparison Table of Various Forms of Harmonic Treatment for VFD's

In multi-pulsed systems, the drive manufacturer will phase shift between multiple front-end rectifiers to cancel harmonics. Some 18 and 24 pulsed systems can achieve Total Harmonic Current Distortion (THID) of < 8%, but they require a larger footprint and can become quite expensive.

Phase shifting transformers can be a very cost effective method of harmonic treatment but require multiple 6-pulse rectifier loads operating simultaneously. A quasi 12-pulse scheme (ie. cancellation of 5th & 7th harmonics) can be created by phase shifting one VFD against a second similar VFD. 18 and 24 pulse schemes require three and four VFD's respectively.

Active filters treat harmonics by measuring the level of harmonic current present in the system and injecting currents of opposite polarity to cancel them. Excellent performance can be achieved but reliability is sometimes an issue and their high cost normally makes their use prohibitive.

Table 11-1 provides a comparison of the various forms of VFD harmonic treatment for different parameters.

12. How does the LINEATOR™ compare to a 12-Pulse or 18-Pulse VFD?

12 and 18-Pulse VFD's use phase shifting transformers and multiple bridges to reduce the current harmonics generated by the VFD. Under balanced voltage conditions, 12-Pulse VFD's can typically achieve current total harmonic distortion levels at full load in the 12% to 15% range while 18-Pulse VFD's can achieve 5% to 8%. Performance will degrade however when the applied voltages are even slightly unbalanced. In addition, the relatively high losses in the phase shifting transformers required for a multi-pulse application will lower the efficiency of the entire VFD package.

The LINEATOR™ applied to a 6-Pulse VFD, on the other hand, will match the performance of the 18-Pulse VFD in reducing current distortion while maintaining high efficiencies. Figures 12-1, 12-2 and 12-3 provide a comparison between a typical 18-Pulse VFD and a LINEATOR™ / 6-Pulse VFD combination. To ensure that a fair comparison was made, the identical 6-Pulse VFD module that was used in the 18-Pulse VFD was also used with the LINEATOR™ as well.

Although the 18-Pulse VFD solution and the LINEATOR™/6-Pulse combination compared favourably with respect to their ability to reduce input current distortion under balanced voltage conditions, the LINEATOR™/6-Pulse combination outperformed the 18-Pulse in many other areas.

Figure 12-1 shows the current distortion measurements with both well balanced and 1% imbalanced supply voltages. The LINEATOR™ / 6-Pulse maintained its excellent performance even with the voltage imbalance of 1%. The 18-Pulse solution had very good performance with a well balanced 3-phase supply but was much less effective with the higher voltage imbalance. Since a slight voltage imbalance is not unusual, the 18-Pulse solution will not always be able to guarantee good performance.

The advantages of the LINEATOR™/6-Pulse are even more evident when a comparison of efficiencies is observed. The LINEATOR™ / 6-Pulse combination achieved efficiencies that were 2% - 3% points higher than the 18-Pulse across the entire operating range. This would translate into very substantial energy savings and an improved payback for the installation.

The VFD's DC bus voltage level is another interesting comparison. At light loads, the capacitors within the LINEATOR™ will tend to boost the VFD's DC bus voltage slightly. The unique reactor design of the LINEATOR™ allows it to achieve its excellent performance while minimizing this voltage boost to 5% or less.

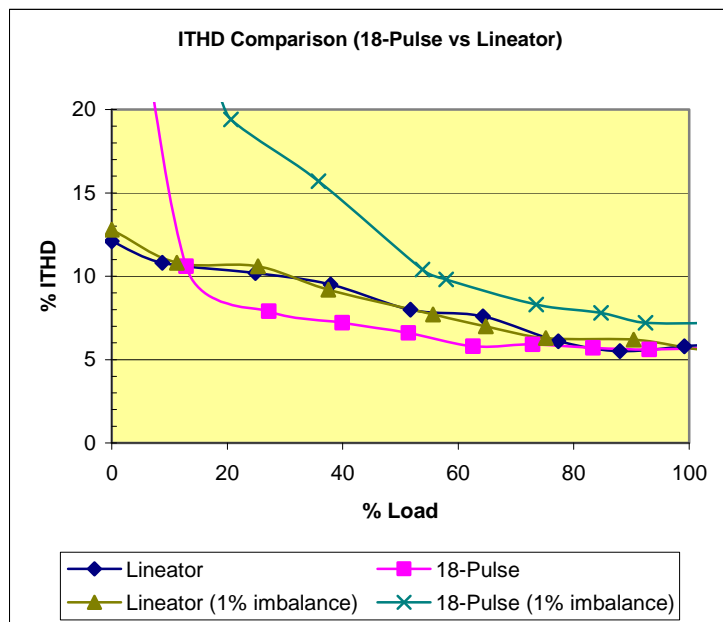

Figure 12-1: Input Current Distortion comparison – 18-Pulse vs

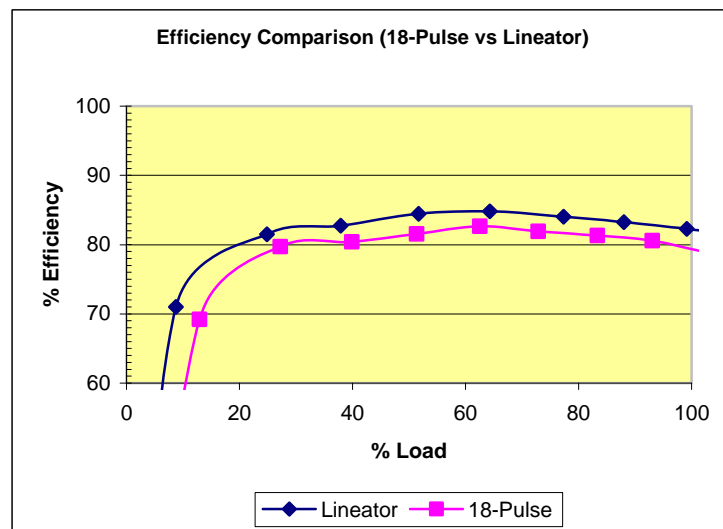

Figure 12-2: Efficiency comparison – 18-Pulse vs LINEATOR™/6-Pulse combination

[<Back to Questions>](#)

What is arguably more important is the DC bus voltage drop at full load. Any impedance added to reduce input current distortion will introduce a voltage drop as the VFD is loaded. Even a 5% AC line reactor will introduce a 5% voltage drop when operated at full load. As the voltage drops, the motor will have to draw more current in order to deliver the power required for the application. As current increases the losses in the motor will increase proportional to the square of this current. The motor will run much hotter and could be susceptible to overheating and pre-mature failure.

As shown in Figure 12-3, the 18-Pulse VFD introduced more than an 8% DC bus voltage drop at full load. This is due to the fact that the 18-Pulse solution requires significantly more impedance to reach the performance level of the LINEATOR™. The total impedance includes the phase shifting transformer, reactors to prevent cross-commutation, an AC reactor ahead of the phase shifting transformer and the AC line reactor within the VFD itself. The impedance of the LINEATOR™ is a combination of the reactor and capacitors resulting in much lower through impedance presented to the VFD. The high number of inductive components in the 18-Pulse VFD also explains why the losses are much higher and efficiency lower.

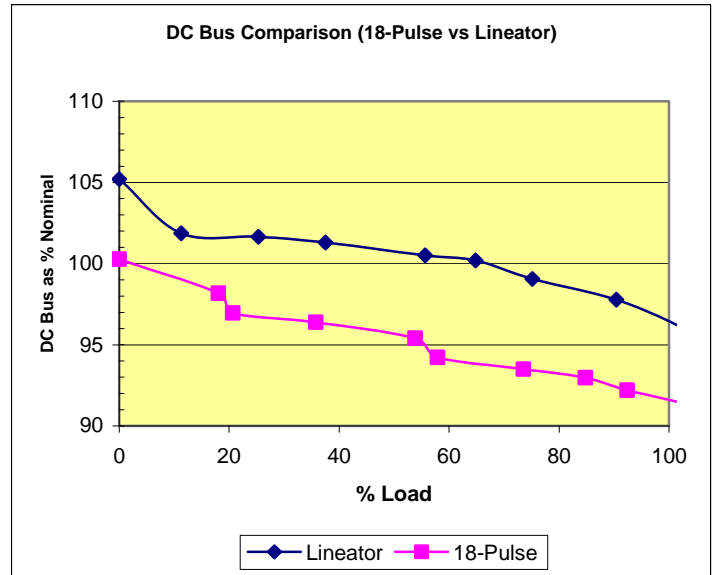

Figure 12-3: DC Bus Voltage comparison – 18-Pulse vs

13. Is the LINEATOR™ compatible with all VFD's?

The standard LINEATOR™ AUHF Type D is designed to reduce the harmonic currents generated by an AC PWM Variable Frequency Drive equipped with a 6-pulse diode bridge rectifier. This includes a VFD that uses an SCR bridge for pre-charge purposes. It is compatible with all PWM AC Drive configurations.

For thyristor bridge (or SCR) applications, such as DC Drives and industrial rectifiers, a Type T LINEATOR should be selected. The Type T unit is designed to accept the phase back angle introduced by the thyristor operation. Reduction of current distortion will be slightly less than that achieved with a Type D unit operating on a diode bridge but still will achieve < 8% ITHD at full load operation.

[<Back to Questions>](#)

14. Is the LINEATOR suitable for generator applications?

In general, generators are reasonably well equipped to handle resistive or inductive loads but do not perform well under highly capacitive loading. This is primarily due to the inability of the generator's excitation controls to adjust to the voltage boost that the capacitors will introduce.

Figure 14-1 shows a typical Reactive Capability Curve for a generator. Reactive power in kVAR as a % of the generator's rated kVA is shown on the X-axis with lagging or inductive loads on the left side and leading or capacitive loads on the right side. Generator loading in KW as a % of rated kVA is shown on the Y-axis. The generator will operate properly with any loading that falls inside the outer curves.

As can be seen, the generator handles well any heavy inductive loads over its entire load range, accepting up to 85% inductive reactance at no load and 60% at full load. It performs less well however, when the loading is capacitive. At no load, capacitive reactive must be less than 20%.

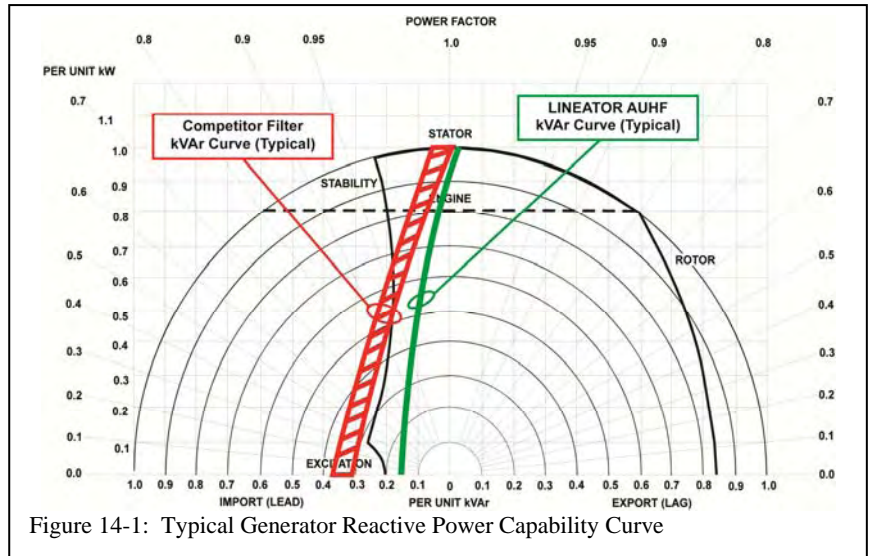

Figure 14-1: Typical Generator Reactive Power Capability Curve

Most competitive passive filters require large capacitor banks in order to achieve the harmonic reduction performance of the LINEATOR AUHF. As a result, they are very rarely suitable for generator applications. The unique configuration of the LINEATOR reactor, on the other hand, allows for a much smaller capacitor bank which ensures that it is compatible with the generator. The green trace in Figure 14-1 shows the maximum capacitive reactance of the LINEATOR AUHF. Even at no load, it is very comfortably lower than the maximum allowed (<15%). The red trace shows the typical capacitive reactance values of competitive filters which falls outside the acceptable limits. As a result, the LINEATOR can be guaranteed to operate without problems on any generator application whereas competitive filters cannot.

15. What if my VFD is equipped with a by-pass?

On Variable Frequency Drive (VFD) installations designed or specified with a bypass circuit, it is recommended that the LINEATOR™ AUHF be installed within the bypass circuit as shown in Figure 15-1.

When the LINEATOR™ is left in the circuit with the VFD bypassed, its through impedance will cause a voltage drop at the motor. This typically will not be enough to under excite or completely ‘starve the motor of voltage’ but will cause the motor to draw more current to compensate for the lower voltage. This could lead to slightly higher slip, heavier losses, lower torque and the potential for overheating. If it is determined that the motor can accept the voltage drop, then the LINEATOR can be left in the circuit when the VFD is being by-passed.

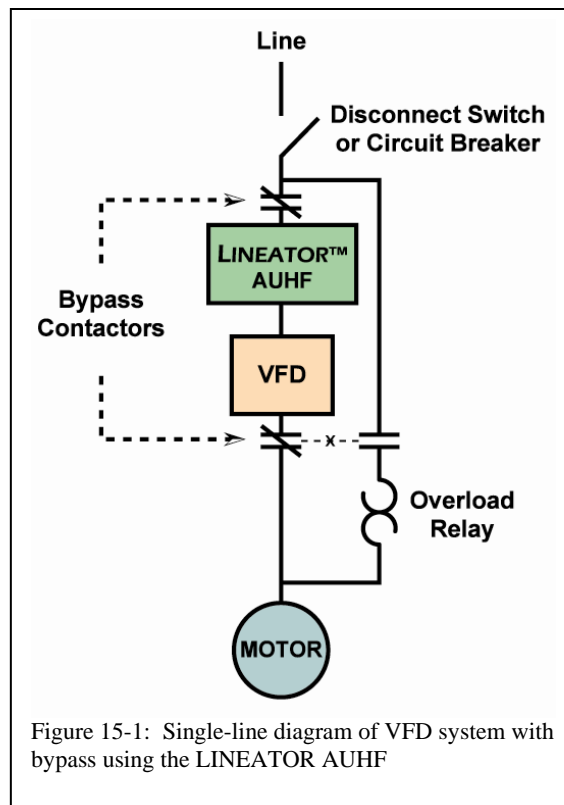

16. Can I use a single LINEATOR to supply multiple VFD's?

A single LINEATOR™ can be used to supply multiple VFD's but in such an application all downstream loads must be VFD's. The trapezoidal output voltage of the LINEATOR™, although ideal for a VFD application, is not suitable for fixed speed motors or other linear loads.

[<Back to Questions>](#)**17. Can I get a computer simulation to demonstrate compliance with IEEE Std 519 or simply to show the LINEATOR™'s effectiveness in a specific application?**

In many applications, it is desirable to perform computer simulations prior to the VFD installation in order to ensure that the design will meet harmonic limits as defined in IEEE Std 519 or some other harmonic standard. In order to provide this service to our customers, Mirus has developed a custom computer simulation program, known as 'SOLV', which has been field proven to provide an accurate prediction of performance provided proper system information is applied. If a computer simulation is required, simply contact Mirus technical support.

[<Back to Questions>](#)**18. What kind of performance guarantee does the LINEATOR™ have?**

Mirus has the best performance guarantee in the industry because, unlike most competitive filters, it is not conditional upon pre-existing voltage distortion or system impedance levels. The standard LINEATOR guarantee is as follows:

MIRUS guarantees that the LINEATOR™ AUHF will perform as advertised to reduce harmonic distortion caused by AC Variable Speed Drives and other non-linear loads equipped with 3-phase, 6-pulse, diode bridge rectifiers. A properly selected and installed LINEATOR™ will:

1. Reduce Current Total Harmonic Distortion (ITHD), as measured at the LINEATOR™ input terminals, to < 8% at full load operation.
2. Reduce Current Total Demand Distortion (ITDD), as measured at the LINEATOR™ input terminals, to < 8% over the entire operating range.
3. Minimize the contribution to Voltage Harmonic Distortion of all VSD's equipped with the LINEATOR™ to < 5% total and < 3% for individual harmonics, as defined by IEEE Std 519-1992.
4. NOT become overloaded by other upstream harmonic sources.
5. NOT resonate with other power system components.
6. NOT have compatibility problems with engine generator sets properly sized for the load.

MIRUS' entire liability and Purchaser's exclusive remedy, at MIRUS' sole discretion, shall be the repair, replacement or full refund of purchase price of the product that does not meet MIRUS' Performance Guarantee and which is returned to MIRUS with a written authorization and a copy of the paid invoice. This guarantee is void if failure of the product has resulted from accident, abuse or misapplication.

In no event shall MIRUS be liable for loss, damage, or expense directly or indirectly arising from the use of the product, or from any other cause, except as expressly stated in this guarantee. MIRUS makes no warranties, expressed or implied, including any warranty as to the merchantability or fitness for a particular purpose or use other than as stated herein. MIRUS is not liable for any consequential or special damages arising out of any breach of warranty, and for any operation or maintenance of the product.

19. What information is required to properly apply the LINEATOR™ AUHF?

Review of the following questions prior to the use of a LINEATOR AUHF on a VFD application will assist in ensuring a trouble-free installation.

1. What is the system voltage and frequency?

The LINEATOR™ is available in both 50Hz and 60Hz and all nominal voltages up to 690V.

2. What is the HP rating of the VFD and motor?

For ease of application, VFD's are typically rated to motor shaft HP. To match this convention, the LINEATOR™ has also been rated to motor shaft HP. Therefore, a 100 HP application would normally call for a 100 HP VFD and a matching 100 HP LINEATOR™. The VFD is designed to handle motor losses as well as motor shaft power while the LINEATOR™ is designed for both motor losses and VFD losses in addition to motor shaft HP. LINEATOR™ performance is guaranteed to be <8% ITHD at full load and <8% ITDD over the full operating range of the VFD. Occasionally, an application will call for a VFD that has been oversized relative to the motor shaft HP (ie. motor is expected to be replaced with a larger one at a later date). The LINEATOR™ should be sized to match this higher rated VFD but there will be a slight compromise in performance since the full load rating of the LINEATOR™ will not be reached when the motor is undersized.

3. What type of load is the motor driving, i.e. fan, pump etc.?

The LINEATOR AUHF is designed to handle any motor load, be it variable or constant torque. Some VFD's are dual rated so care should be taken to match the appropriate VFD rating for the load.

4. Is the rectifier a simple diode bridge (as in standard PWM AC Drives) or a thyristor bridge (as in DC Drives or industrial rectifiers)?

The LINEATOR AUHF is available in two model types – Type D and Type T. Type D is used on standard diode bridge rectifiers and Type T is used on thyristor bridge rectifiers (or SCR). Typically Type T units will be one size larger than their Type D equivalent.

5. What is the VFD model number and manufacturers name?

Basic information on the type of VFD will help ensure that the appropriate LINEATOR™ model is chosen.

6. What is the KVA rating and %Z of the transformer or generator feeding the VFD?

If we can collect this type of information along with a single line diagram we can use MIRUS' SOLV computer simulation software to predict the level of harmonics with and without the LINEATOR™ installed to demonstrate its ability to meet IEEE Std 519 limits.

7. Does the VFD have a bypass circuit arrangement?

If the VFD has a bypass circuit, it is recommended that the LINEATOR™ be connected to the VFD such that it can be bypassed along with the VFD. However, if it is determined that the motor can withstand the voltage drop introduced by the LINEATOR™, it may be left in the circuit during VFD by-pass.

8. Will the LINEATOR™ be used on multiple VFD's or have loads connected downstream that are not VFD's?

A single LINEATOR™ can be used to supply multiple VFD's but in such an application all downstream loads must be VFD's. The trapezoidal output voltage of the LINEATOR™, although ideal for a VFD application, is not suitable for fixed speed motors or other linear loads.

Reasons for selecting MIRUS Harmonic Mitigating Transformers in Lieu of K-Rated

The first signs of the incompatibility between conventional building power distribution systems and personal computers became obvious in the mid-1980s as more and more personal computers appeared in the workplace. One decade later, personal computers, monitors, powerful workstations, laser printers, and other modern electronic office equipment typically form a large portion of the electrical load in a building. Because these loads are very non-linear, their load currents are rich in harmonics, causing problems for both the power distribution system and for the electronic equipment itself.

The ill effects due to current harmonics generated by these non-linear loads include:

1. **Large currents in the neutral wires of the power distribution system.** The neutral current will generally be larger than the current in any of the phase wires. Because only the phase wires are protected by circuit breakers or fuses, this is a very real fire hazard.
2. **Overheated electrical supply transformers.** Overheating shortens the life of a transformer and will eventually kill it. When a transformer fails, the cost of lost productivity during the emergency repair time far exceeds the replacement cost of the transformer itself.
3. **Poor power factor.** The harmonic currents caused by the non-linear loads do not carry any real power (kW) even though they do increase the volt-amperage (kVA). This lowers the power factor ($PF = kW/kVA$) at the building electrical service entrance. Electrical utilities have a monthly penalty charge for major users with a power factor less than 0.9.
4. **Lowered reliability of computer systems.** Distorted 120VAC supply voltage and increased the neutral-to-ground voltage may cause hardware problems which often appear at first to be software problems. IEEE Std. 519-1992 recommends that the voltage distortion for computer use be limited to a maximum of 5% total harmonic distortion (THD) and that the largest single harmonic not exceed 3%.

The electrical industry's first response to these four problems was to double the ampacity (current carrying capacity) of the neutral conductors so that they would not burn-up. This is becoming a standard design practice in office buildings.

The second response was to beef-up the distribution transformer so that it would not fail due to the higher heat losses caused by the harmonic currents flowing through it. These transformers are now known as k-factor rated transformers. The k-factor is a mathematical formula which predicts that the eddy current losses in a transformer will be increased in direct proportion to the sum of the products of each harmonic current amplitude squared multiplied by its harmonic number squared.

Doubling the neutral and using a k-factor rated transformer will solve the electrical safety half of the harmonics problem. **Unfortunately, these two steps do nothing to solve problem 3, poor power factor, nor problem 4, lowered computer system reliability.**

On the other hand, using a combination of **MIRUS Harmonic Mitigating transformers**, doubling the neutrals, and keeping the distribution panels close to the transformers will solve all four problems at once. Here's why.

The **MIRUS transformer is an isolation transformer with a special secondary winding configuration which minimizes the voltage distortion caused by the 3rd and 9th current harmonics that make up the major portion of the neutral current. It is suitable for supplying loads up to k-factor 20.**

The **MIRUS Harmony-1™ transformer** can be manufactured with either a zero degree or a 30 degree phase shift (at the fundamental frequency of 60Hz) between its input and output windings. The 30 degree phase shift at the fundamental results in a 180 degree phase shift for the 5th, 7th, 17th, and 19th harmonic currents. We can take advantage of this fact to **cancel these harmonic currents from one half of the building against those from the other half.** This can be done by supplying one-half of the building through Harmony-1™ transformers with a zero degree shift (zero degrees for the fundamental and all the harmonics) and the other half through Harmony-1™ transformers with a 30 degree shift at the fundamental (180 degrees for 5th, 7th, 17th, and 19th harmonics). This will remove the balanced portions of all four of the largest current harmonics (3rd, 5th, 7th, and 9th). **There will be a substantial improvement in power factor, solving problem 3.** For even better performance, the Harmony-2™ transformer produces the cancellation of 5th & 7th harmonics at the secondary of the transformer using 2 outputs.

Voltage distortion is caused by the interaction of the harmonic currents with the various impedances of the distribution systems at the harmonic frequencies. Canceling the 3rd, 5th, 7th, and 9th harmonic currents with the Harmony-1™ transformers will result in a worthwhile improvement in voltage distortion level. Each application is different, but typically the new voltage distortion level will be about half of the original level and comfortably within the IEEE recommended maximum of 5%. As a final step, keeping the distribution panels close to the transformers will limit the length of the 120/208V, 4-wire runs. This will minimize the neutral-to-ground voltage which can develop. Hence, **computer system reliability is improved, solving problem 4.**

In summary, using the basic k-factor rated transformer will permit solving just the first two problems. Using MIRUS Harmonic Mitigating transformers will permit solving all four problems, ensuring that the computer system loads and the power distribution system are completely compatible with each other.

How the Harmonic Mitigating Transformer Outperforms the K-Rated Transformer

Tony Hoevenaars, P.Eng., Vice President
MIRUS International Inc.



Abstract

The use of K-Rated transformers has become a popular means of addressing harmonic related overheating problems where personal computers, telecommunications equipment, broadcasting equipment and other similar power electronics are found in high concentrations. These non-linear loads generate harmonic currents which can substantially increase transformer losses. The K-Rated transformer has a more rugged design intended to prevent failure due to overheating. Unfortunately, a transformer designed simply to protect itself fails to address the other important problems associated with harmonics. Specifically, in order to prevent high voltage distortion levels from adversely affecting the equipment loads, the transformer must be capable of canceling harmonic currents and fluxes within its windings. Harmonic Mitigating Transformers (HMT's) will not only prevent transformer overheating failures but will also reduce failures in connected equipment by ensuring that IEEE Std 519 voltage distortion limits are met throughout the power distribution system.

1. Introduction

It is quite commonly known that harmonics generated by non-linear loads can cause serious overheating problems in standard distribution transformers. Even under much less than fully loaded conditions, transformers have been known to fail catastrophically. One of the main reasons for this is that harmonic currents will dramatically increase the eddy current losses in a transformer. The relationship is as follows^[1]:

$$P_{EC} = P_{EC-1} \sum_{h=1}^{h_{max}} I_h^2 h^2$$

Where: P_{EC} = total eddy current losses
 P_{EC-1} = eddy current losses at fundamental
 I_h = rms current at harmonic h
 h = harmonic number

This has prompted transformer manufacturers to build more robust designs which can tolerate the additional harmonic losses. In the interest of standardization, a rating scheme has been adopted known as K-factor. K-factor reflects the increase in eddy current losses and is defined as follows^[2]:

$$K = \sum_{h=1}^{h_{max}} I_h^2 h^2$$

Where: I_h = rms current at harmonic h, in per unit of rated rms current

A K-rated transformer then, is one that can be loaded to its full load rating when servicing a non-linear load with a K-factor rating no greater than the transformers K-rating. Standard K-factor ratings are 4, 9, 13, 20, 30, 40 and 50.

It is important to note that specifying an extremely high K-rating is, in itself, not necessarily a good thing. For example, a K-30 transformer is only required if the load it services is actually a K-30 load and if it is expected to operate near full load rating. Specifying too high a K-rating will result in an oversized transformer which can introduce problems such as very high inrush currents, excessive fault levels, higher core losses and a larger footprint.

The harmonics problem however, is much more than simply the overheating of electrical distribution equipment. When servicing a high concentration of non-linear loads, power distribution systems can experience a wide variety of problems, which include:

1. Power factor correction capacitor failures due to overloading and / or system resonance
2. Overheating cables, transformers and other distribution equipment reducing their life span
3. High voltage distortion (typically in the form of flat-topping) especially when operating on weak sources, such as emergency generators or UPS systems

4. False tripping of circuit breakers
5. Premature failure of rotating equipment (motors, generators, etc.)
6. Misoperation or component failure in PLC's, computers or other sensitive loads

Of all the problems listed above, those resulting from high voltage distortion are often the most severe and generally the most difficult to identify.

2. How Harmonic Currents Create Voltage Distortion

Voltage distortion is created as harmonic currents, generated by non-linear loads, pass through the impedance of a power distribution system. Current at any frequency flowing through an impedance will result in a voltage drop in the system at that frequency. This is a simple application of Ohm's Law, $V_h = I_h \times Z_h$, where:

- V_h = voltage at harmonic number h
- I_h = current at harmonic number h
- Z_h = impedance of system to harmonic h

The accumulative effect of the voltage drops at each frequency produces voltage distortion. A common term used to indicate the amount of waveform distortion is *Total Harmonic Distortion*, or *THD*. THD is expressed in percent and for power systems can be applied to both voltage and current. Voltage total harmonic distortion (V_{thd}) is defined as a root mean square of all the harmonic voltage drops and is expressed as follows:

$$V_{thd} = \frac{\sqrt{V_2^2 + V_3^2 + V_4^2 + V_5^2 + \dots}}{V_1} \times 100\%$$

Current distortion is a measure of the combined effect of the various harmonic currents present:

$$I_{thd} = \frac{\sqrt{I_2^2 + I_3^2 + I_4^2 + I_5^2 + \dots}}{I_1} \times 100\%$$

Voltage distortion then is a function of both the system impedance and the amount of harmonic current in the system. High system impedance due to long cable runs, high impedance transformers, generators, UPS systems, etc. usually causes high voltage distortion levels.

The basic relationship between current and voltage distortion can be seen by examining the waveforms

themselves. A typical non-linear load, the Switch-mode Power Supply (SMPS) is shown in Figure 1. This device draws current only during the peaks of the voltage waveform while charging the smoothing capacitor. As the applied voltage drops during the rest of the cycle, the capacitor discharges to support the load. The pulses of current which recharge the capacitor cause voltage drops which clip-off or flat-top the voltage peaks.

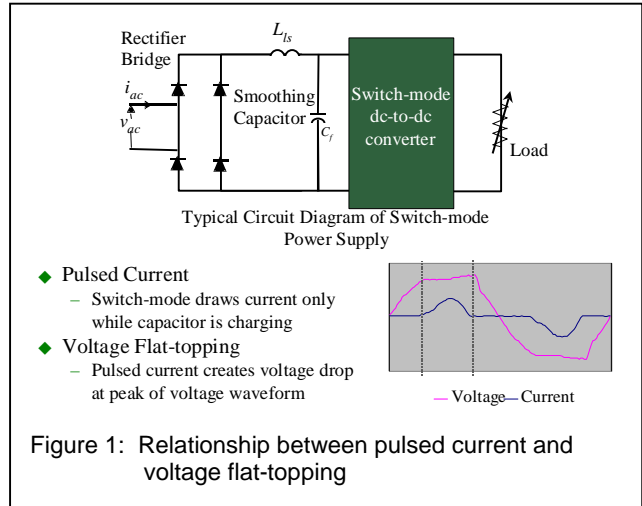

3. The Effect of Voltage Flat-topping on the Switch-mode Power Supply

How voltage flat-topping affects the operation of an SMPS is a fairly controversial topic. Most equipment manufacturers specify $< 5\% V_{thd}$ in their installation manuals but readily admit that many installations exceed these recommendations. IEEE Std 519 also lists $5\% V_{thd}$ as a recommended limit and states, “Computers and allied equipment such as programmable controllers frequently require ac sources that have no more than a 5% harmonic voltage distortion factor, Higher levels of harmonics result in erratic, sometimes subtle, malfunctions of the equipment that can, in some cases, have serious consequences.”

Often the equipment appears to operate normally but the long-term effect of exposure to a severely distorted or flattened voltage waveform is rarely considered. A drop in peak voltage will directly reduce the DC bus voltage within an SMPS. Figure 2 shows how the DC bus voltage depends directly upon the peak value of the supply voltage rather than

upon its average or RMS values. During each voltage half cycle, the smoothing capacitor is charged by the voltage peak. It then discharges to support the DC voltage as the supply voltage drops to zero and returns to its peak value. The result is a DC voltage with a slight DC ripple.

When the SMPS is supplied by a sinusoidal voltage waveform, the DC bus voltage remains high. When the peak is flat-topped however, the DC bus voltage will be lowered proportionately. With a reduced DC

bus voltage, the SMPS must draw more current to satisfy the power demands of the load ($P = V \times I$). This increase in current will increase the internal I^2R losses and the heat these losses produce. Components within the SMPS will then run hotter and can fail prematurely.

Another negative effect of a lower peak supply voltage is reduced ride-through capability (see Figure 3). With a full peak voltage, the smoothing capacitor in the SMPS will often have enough

charged energy to support the load during a brief power interruption. This can explain why a personal computer is unaffected when lighting in the area flickers during a thunderstorm or other inclement weather condition.

With a flattened voltage waveform however, the smoothing capacitor will not get fully charged. With less stored energy, this capacitor may no longer be capable of supporting a load during the full duration of a power interruption and the equipment can shutdown.

The problem of voltage flat-topping becomes even more severe when weak sources such as standby generators or UPS systems are used. This is due to their higher source impedance. A generator's impedance, for instance, can be several times higher than that of a distribution transformer. Therefore, if under normal utility power, voltage distortion at an emergency transfer switch is around 3% or 4%, it would very likely be over 10% when transferred to the standby generator during a power interruption. Often harmonic problems become obvious only when operating under emergency conditions.

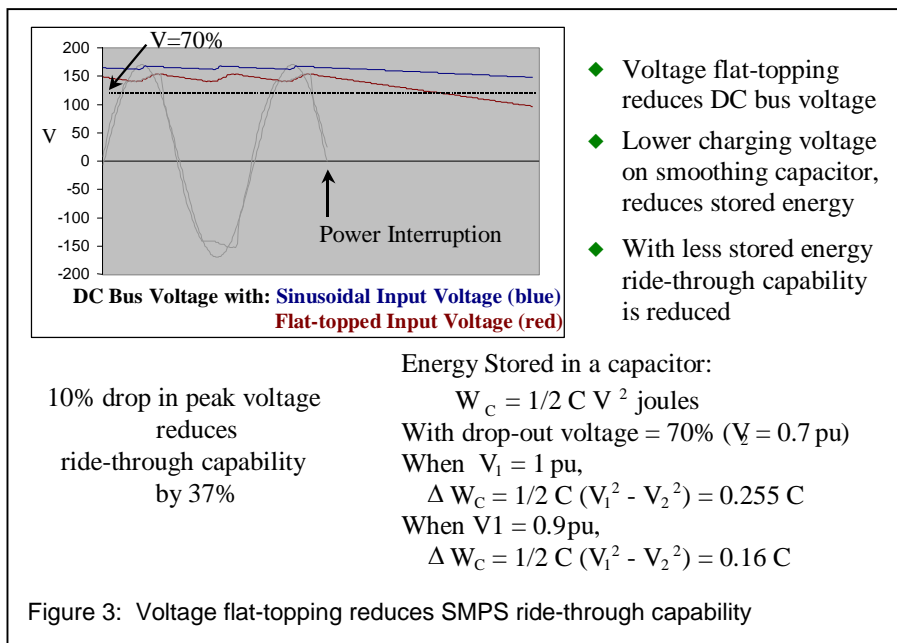
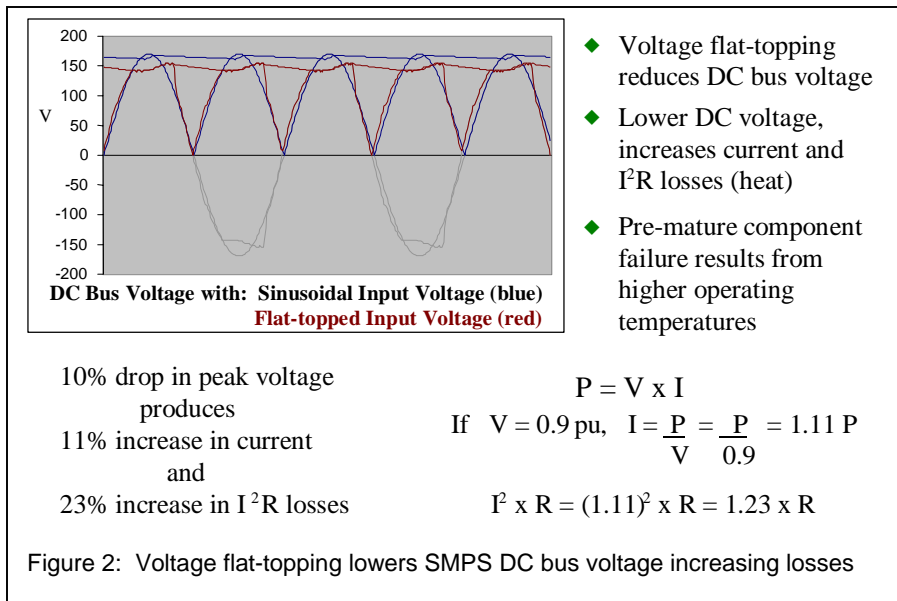

High voltage distortion has been known to prevent closed transition returns to utility when power is restored after an interruption. The highly distorted voltage waveform at the generator can prevent synchronization with the normal power source. Without proper synchronization, the two sources cannot be paralleled and therefore, the load must be dropped before it can be transferred back to normal power^[3].

4. Using HMT's to Prevent Voltage Flat-topping

Harmonic Mitigating Transformers are specially designed to reduce system voltage distortion in addition to reducing the heating effects caused by the harmonic currents. This is accomplished by canceling load generated harmonic fluxes and currents within the transformers windings:

1. Zero sequence harmonic currents, which include the 3rd, 9th and 15th, are prevented from circulating in the primary windings by canceling their fluxes within the secondary windings.
2. Single output HMT's are available in 2 models with differing phase shifts which when paired will induce cancellation of 5th, 7th, 17th & 19th harmonic currents upstream.
3. Dual output HMT's phase shift to cancel the balanced portion of 5th, 7th, 17th & 19th harmonic currents within their secondary windings.
4. Three output HMT's phase shift to cancel the balanced portion of 5th, 7th, 11th & 13th harmonic currents within their secondary windings.
5. Reduction of harmonic currents in the primary windings and upstream of the HMT reduces the harmonic voltage drops and voltage distortion these drops produce.
6. Losses are also reduced because the transformer and upstream distribution equipment is subjected to less harmonic current.

This means that an HMT will produce significantly less voltage distortion than a conventional or K-rated transformer when servicing similar non-linear loads. In Table 1, the performance of various HMT models is compared with a typical K13 transformer. Included as well, is a simple dual output phase shifting transformer (Forked Wye) which is also finding application as a harmonic canceling transformer. This transformer has dual outputs which are phase shifted by 30° to cancel the balanced 5th and 7th harmonic currents in much the same manner as the dual output HMT. The principal difference from the HMT is in the treatment of the 3rd and other triplen harmonics. Where the HMT prevents these currents from circulating in its primary windings, the Forked Wye does not. This means that voltage distortion at the 3rd harmonic will be just as high as it would be in the K13 and conventional transformer.

	V _{thd} at Transformer Output		
	Full load	75% load	50% load
K13 Transformer	10.5%	7.8%	5.2%
Forked Wye	7.9%	5.9%	3.9%
Single Output HMT	6.9%	5.2%	3.4%
Dual Output HMT	3.8%	2.8%	1.9%
Three Output HMT	3.6%	2.7%	1.8%

Table 1: Modeling of Voltage Distortion at the output of 112.5 KVA Transformers with K-13 load profile.

Computer modeling was used to determine the voltage distortion that would appear at each transformers output when servicing a K-13 non-linear load of I_{thd} = 88%. As can be seen, the HMT transformers produced lower voltage distortion than both the K13 and the Forked Wye. The multiple output HMT's achieved the best results by treating 5th, 7th and other higher order harmonics in addition to the triplens (3rd, 9th & 15th).

With this load profile, the K13 transformer will meet the 5% V_{thd} limit only when loaded to less than 50%. The multiple output HMT's, on the other hand, can be fully loaded without overly distorting the voltage waveform and the single output HMT can be loaded to 75% before exceeding 5% V_{thd}.

This analysis supports the use of multiple output HMT's when a distribution system is required to service a high concentration of non-linear loads. This would include computer rooms, call centers, broadcasting studios, telecommunications sites, Internet Service Providers and hospitals to name a few. When the loading is not expected to be as severe, the single output HMT may prove to be sufficient to prevent problems from developing. In any event, the K13 transformer is not a suitable alternative.

5. Case Studies Demonstrating how an HMT will Eliminate Equipment Failure by Reducing Voltage Distortion

A Chicago area bank was troubled by consistent failures of equipment power supplies in one of its critical communications rooms. Poor power quality was considered a potential cause of the problem but it was believed that the 75 kVA UPS that serviced the load should have addressed all of the power quality needs of the equipment.

Charles Andersen of ATA, a local electrical testing company, was called upon to monitor the site in an attempt to determine the cause of the equipment failures. Continuous monitoring over a period of 20 days, uncovered no troublesome impulses, surges, sags or power interruptions. An extensive review of the grounding system also produced no significant findings. During this investigation period the equipment failures continued. What the monitoring did identify however, was that the voltage downstream of the UPS was severely flat-topped with V_{thd} consistently above 8%.

To resolve the high voltage distortion problem, a 75 kVA, three output HMT was installed downstream of the UPS. By treating the entire spectrum of odd order harmonics (up to and including the 15th) the HMT was able to reduce the current distortion of the load from 65% to less than 10%. The direct result of this current distortion reduction was a dramatic drop in voltage distortion to less than 4%. With the installation of the HMT, power supply failures dropped from an average of 5 per month to less than 1. In time, these are expected to reduce even further as the residual effect of the long term exposure to distorted voltage begins to subside.

In another application, dual output HMT's were used to service a Test Area at a major silicon chip manufacturer. Prior to the installation of the HMT's, consistent failures in the equipment being tested were resulting in annual repairs in the order of \$200,000. The improvement in voltage distortion that accompanied the HMT installation virtually eliminated the equipment failures and the savings in maintenance costs more than justified the HMT purchase.

6. Conclusion

With their ability to treat both power quality and overheating harmonic concerns, Harmonic Mitigating Transformers significantly outperform their K-rated cousins. Power distribution systems designed with HMT's are capable of servicing any level of non-linear loading without suffering negative consequences. This should justify more widespread use of the HMT in applications where high concentrations of non-linear loads are found. Continued use of K-rated transformers, on the other hand, will lead to distribution systems that are incapable of being fully utilized without distorting the voltage waveform above recommended maximum levels.

7. References

1. IEEE Emerald Book, Recommended Practice for Power and Grounding Sensitive Electronic Equipment, IEEE Std 1100-1992
2. IEEE std 519-1992, Recommended Practices and Requirements for Harmonic Control in Electrical Power Systems
3. Practical Guide to Quality Power for Sensitive Electronic Equipment, 2nd Edition, EC&M Books
4. Taming the Rogue Wave: Techniques for Reducing Harmonic Distortion, Tony Hoevenaars, P. Eng., Published in EC&M Magazine June 1997



Energy Savings with an Energy Star Compliant Harmonic Mitigating Transformer

Tony Hoevenaars, P.Eng,
Vice President
Mirus International Inc.

The United States Environmental Protection Agency's Energy Star program has gained tremendous popularity since its inception in 1992. The Energy Star label is now recognized by many as a sign of energy efficiency as it appears across more than 30 different product areas such as computer equipment and household appliances. As society continues to work towards environmentally friendly and self sustaining energy solutions, this trend will certainly continue.

In 1998 Energy Star expanded its program to include Commercial and Industrial (C&I) transformers. A voluntary efficiency standard developed by the National Electrical Manufacturers Association (NEMA), known as NEMA TP 1-1996, *Guide for Determining Energy Efficiency for Distribution Transformers*, was adopted for the program. States such as Massachusetts, Wisconsin, Minnesota, California, New York and most recently Oregon and Hawaii, have established NEMA TP 1 in their state minimum efficiency standards or now include TP 1 as a provision in their commercial energy codes¹.

It is important to note that the NEMA TP-1 standard was based upon linear loading and is optimized for 35% load levels. This criteria has merit when the load is, in fact, linear because surveys have shown that many distribution transformers in North America are only lightly loaded. However, if the transformer is more heavily loaded and/or its load is primarily non-linear, designing to optimal efficiencies at 35% linear load may actually result in higher losses and lower efficiencies.

Since non-linear loads, which include computers, variable frequency drives and other power electronic equipment now constitute a very large component of today's load, simply meeting NEMA TP 1 and Energy Star compliance is often not a sufficient means of assuring optimal efficiency levels are met. This is because non-linear loads can very significantly increase harmonic losses and NEMA TP 1 was not intended to address these additional losses. As a result, transformers

designed for non-linear loads, such as K-rated and Harmonic Mitigating, are specifically exempted in NEMA TP 1. And since most loads today are non-linear, this means that meeting TP 1 and Energy Star compliance, in itself, will not ensure that optimal efficiency is achieved in many actual applications.

To address this, Mirus International has developed a line of Harmonic Mitigating Transformers (HMT's) that ensure optimal efficiency levels are reached with either linear or non-linear loading and at lightly loaded or heavily loaded levels. This is accomplished through two principle strategies: (i) transformer windings which are configured such that critical harmonics are cancelled within the transformer secondary and (ii) linear load efficiencies which meet NEMA TP 1 levels, not only at 35% load, but in the full operating range from 35% to 65%.

NEMA TP 1-1996 Transformer Efficiency Standard

NEMA TP-1 defines minimum efficiency levels for transformers with linear loads at 35% loading. This criteria was chosen based on surveys which indicated that the average loading on distribution transformers in North America is about 35%. The efficiency limits vary by transformer size but are generally in the 98% range. In choosing 35% loading, NEMA TP-1 puts extra emphasis on no-load (core) losses rather than load (copper) losses. With emphasis on no-load losses, NEMA TP-1 does not adequately address harmonic losses and therefore, specifically exempts transformers which service non-linear loads. The following are taken from its exemption list:

- c. Drives transformers, both AC and DC²
- d. All rectifier transformers and transformers designed for high harmonics
- g. Special impedance, regulation and harmonic transformers

The reason that transformers designed for high harmonics are exempted is that harmonics will

dramatically increase load losses (I^2R and eddy current) and have very little effect on no-load losses. Therefore, NEMA TP-1's emphasis on no-load losses can be counter productive when supplying non-linear loads. To meet the efficiency limits, a manufacturer must optimize for lower no-load losses, often at the expense of higher load losses. For example, one common way of reducing no-load losses is to reduce the flux density by adding more steel to the transformer's core. With a larger core, each turn of the transformer's windings must cover a larger circumference. The extra length of copper winding adds resistance which increases I^2R load losses. This can significantly INCREASE losses and REDUCE efficiencies when supplying non-linear loads at load levels above 35%.

Why Design for Peak Efficiency over a Load Range of 35% to 65%?

NEMA TP 1's emphasis on linear load efficiency under lightly loaded conditions is justified only if the power system is indeed lightly loaded and consists primarily of linear loads. If the load is non-linear or the system is more heavily loaded, optimizing efficiency at 35% can prove to be an inferior design resulting in higher losses rather than lower ones.

This problem can be averted if the transformer is designed for optimum efficiency over a wider load range and if its windings are configured to reduce harmonic losses. Figure 1 provides linear load efficiency curves for a standard 75 kVA Energy Star compliant TP 1 delta-wye transformer and for a 75 kVA Energy Star compliant Harmony-1E Harmonic Mitigating Transformer. Both meet the

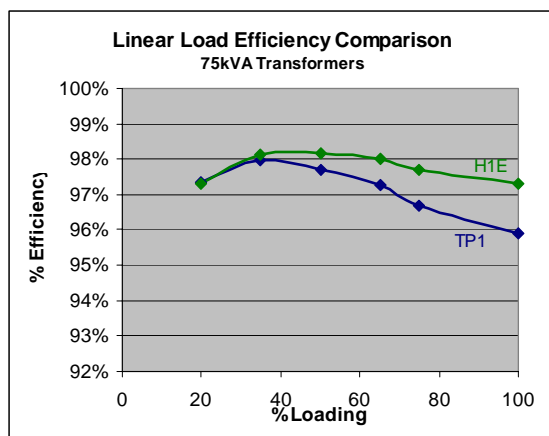

Figure 1: Linear load efficiency comparison

NEMA TP 1 efficiency limit of 98% at 35% linear load but the efficiency of the standard unit drops off rapidly under more severe loading. By maintaining TP 1 efficiency over the entire range from 35% to 65%, the Harmony-1E is more efficient at all load levels above 35%.

This improved performance is magnified when the load is non-linear. In Figure 2, non-linear load efficiencies are shown using the same transformers but with a K-9 load profile ($I_{thd} = 80\%$) which is typical of computers and other 120V power electronic equipment. Under this loading, the Harmony-1E provides significantly more energy savings especially as the load increases on the transformer.

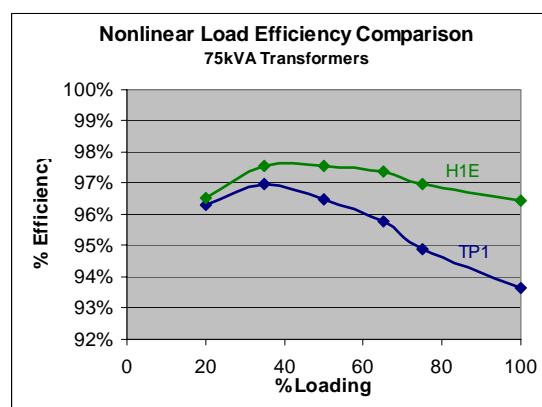

Figure 2: Non-linear load efficiency comparison

How Harmonics Increase Transformer Losses

Harmonics generated by non-linear loads will dramatically increase the losses in a conventional delta-wye distribution transformer. These added losses increase the monthly utility bill, indirectly add to environmental pollution and can shorten the transformer life by increasing its operating temperature.

To address the overheating transformer problem, K-rated delta-wye transformers are now frequently used in non-linear load applications. These transformers are designed to withstand the additional heat generated by the harmonic losses but will actually reduce these losses only marginally. Harmonic Mitigating Transformers, on the other hand, substantially reduce harmonic generated losses by using winding configurations that promote harmonic flux cancellation.

Transformer loss components include no load (P_{NL}) and load losses (P_{LL}). The no load losses are transformer core losses. They are essentially independent of the load current and its harmonic content. Furthermore, no load losses are affected only marginally by voltage harmonic distortion and therefore, can usually be neglected when determining the effect of harmonics on transformer losses. Load losses however, vary with the square of the load current and are very significantly affected by harmonic content.

Load losses consist primarily of I^2R copper losses (P_R) and eddy current losses (P_{EC}). Harmonics increase these losses in the following ways:

1. Copper Losses, I^2R

Harmonic currents are influenced by a phenomenon known as skin effect. Since they are of higher frequency than the fundamental current they tend to flow primarily along the outer edge of a conductor. This reduces the effective cross sectional area of the conductor and increases its resistance. A higher resistance leads to higher I^2R losses. Proximity effect between adjacent conductors compounds this problem by further distorting the current distribution in the conductors.

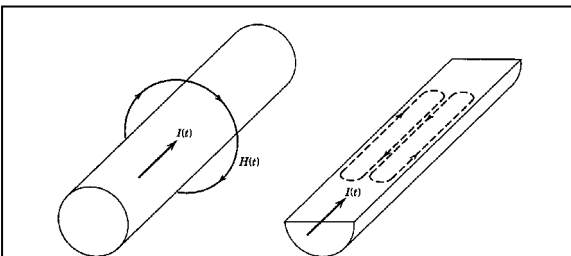

Figure 3: Skin effect in a conductor³

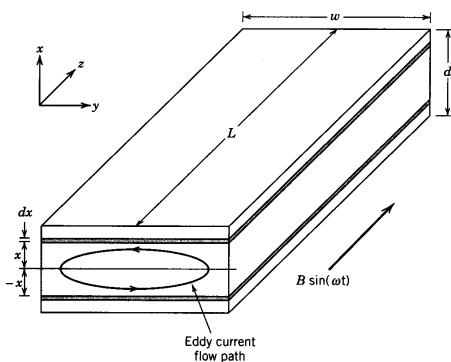

Figure 4: Eddy currents in the steel laminations of a transformer³

2. Eddy Current Losses

Stray electromagnetic fields will induce circulating currents in a transformer's windings, core and other structural parts. These eddy currents produce losses which increase substantially at the higher harmonic frequencies. The relationship is as follows:

$$P_{EC} = P_{EC-R} \sum_{h=1}^{h_{max}} I_h^2 h^2$$

Where:

P_{EC} = Total eddy current losses for non-linear load

P_{EC-R} = Eddy current losses at rated linear load

I_h = Ratio of rms current at harmonic h to full load current of transformer

h = harmonic #

For linear loads, eddy currents are a fairly small component of the overall load losses (approx. 5%). With non-linear loads however, they become a much more significant component, sometimes increasing by as much as 15 to 20x.

In addition to increasing conventional losses in a transformer, phase-to-neutral non-linear loads will also produce excessive primary winding circulating currents. The 3rd and other odd multiples of the 3rd harmonic (referred to as triplens) are zero phase sequence in nature and as such become trapped in the primary delta windings of conventional and K-rated transformers. I^2R and eddy current losses increase as these currents circulate in the transformers primary windings.

How HMT's Reduce Harmonic Losses

Harmonic Mitigating Transformers save energy by reducing losses in the following ways:

1. Zero phase sequence harmonic fluxes are cancelled by the transformers secondary windings. This prevents triplen harmonic currents from being induced into the primary windings where they would circulate. Consequently, primary side I^2R and eddy current losses are reduced.
2. Multiple output HMT's cancel the balanced portion of the 5th, 7th and other harmonics

within their secondary windings. Only residual, unbalanced portions of these harmonics will flow through to the primary windings. Again I^2R and eddy current losses are reduced.

3. HMT's are designed to be highly efficient at 60Hz as well as at harmonic frequencies. Energy Star compliant models meet NEMA TP-1 energy efficiency minimums at 35% loading. This is typically achieved by reducing core losses but not at the expense of higher copper losses.

Calculating Transformer Losses under Non-Linear Loading⁴

Calculating transformer losses under non-linear loading is a fairly complex process. The following procedure is commonly followed:

1. Determine the core loss at fundamental (60 Hz) frequency - P_{NL} .
2. Calculate I^2R losses in both the primary and secondary windings - P_R .
 - a) Determine the AC resistance at the fundamental frequency for the specific wire size and material used in the primary and secondary windings.
 - b) Determine the effective AC resistance due to skin effect at each of the harmonic frequencies.
 - c) Calculate the I^2R losses for each harmonic at the load K-factor chosen and the percent loading of the transformer.
 - d) Total all the I^2R losses
3. Calculate eddy current losses in both primary and secondary windings - P_{EC} .
 - a) Determine the eddy current loss at the fundamental frequency (P_{EC-1}). This is typically 5% of the I^2R loss at the fundamental frequency.
 - b) Calculate I^2h^2 for each harmonic at the load K-factor chosen and the percent loading of the transformer.
 - c) Calculate total eddy current losses by the following formula,

$$P_{EC} = P_{EC-1} \sum_{h=1}^{h_{max}} I_h^2 h^2$$

4. Total all loss components,
 $P_L = P_{NL} + P_R + P_{EC}$

Energy Savings Comparison

Figure 5 provides an example of the energy savings that can be realized when HMT's are used in lieu of conventional or K-rated transformers. A K-9 load profile, typical of a high concentration of computer equipment (I_{thd} = 80%), was selected for the analysis. Losses were calculated for various types of 75 kVA transformers at varying load conditions. In the graph, Conv is a conventional delta-wye transformer, K-13 is a K-13 rated delta-wye and H1E is a Harmony-1E™ single output Energy Star compliant HMT.

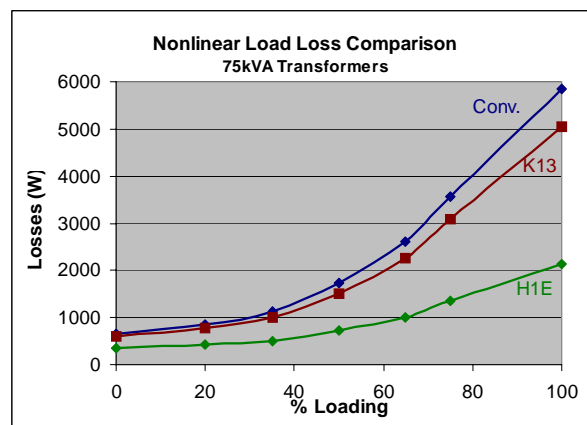

Figure 5: 75 kVA Transformer losses at various loading conditions with non-linear K-9 load profile.

The chart shows how energy savings become more and more substantial as a transformer's load increases. This is logical since it is the load losses which are most affected by the harmonic currents and these are proportional to the square of the current (I^2R and I^2h^2).

Figure 6 further emphasizes how transformer efficiencies are affected by non-linear loading. It compares the performance of various types of transformers with linear loading (K-1) and non-linear loading (K-9). The efficiencies of the conventional and K-13 transformer are much lower when they are subjected to a load with a K-9 profile, especially under the heavier loading conditions.

Determining the amount of energy savings associated with a reduction in harmonic losses requires information on the Electric Utility rate and the load's operating profile. These parameters can vary quite substantially depending upon the location of the facility and the specific application.

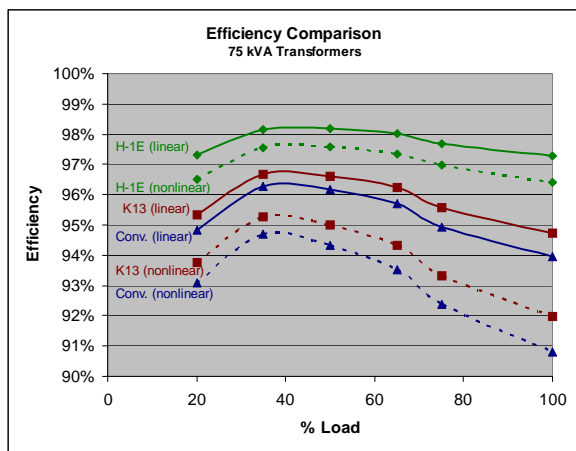

Figure 6: Energy Efficiencies for various types of 75 kVA transformers supplying linear (K-1) loads and non-linear (K-9) loads under varying load conditions.

is required by the building's air conditioning system to remove the heat produced by the transformer losses. The calculation used is shown below the table.

This scenario could be typical of an office environment with a high concentration of computer loads and with the transformer located in air conditioned space. The requirement to cool the heat produced by the transformer's losses is typically 30% to 40% of the power in the losses (thus the 1.35 multiplier in calculation of \$/yr Savings). Paybacks were calculated based on estimated transformer costs and would result in recovering the Harmony-1E premium many times over based on the transformer's life expectancy of 30 to 40 years.

Table 1 shows the energy savings that can be realized when a Harmony-1E HMT is compared with a typical K-13 transformer. As in the previous examples, the transformers are 75 kVA and the non-linear load profile is that of a typical K-9 load. The monetary savings are based on the equipment operating 12 hours per day, 260 days per year at an average Utility rate of \$0.07 per kWhr and assumes that additional cooling energy

Table 2 provides another example. In this case, a lower harmonic content K-4 load profile was used with the equipment operating 24 hrs/day, 365 days a year and the transformer located in air conditioned space. An example of such a location might be a Broadcasting Facility or Data Center. As can be seen, paybacks are even more attractive.

Transformer	% Load	Losses (Watts)			Annual Consumption		Transformer Cost (Est.)	Payback on HMT Premium
		NLL	LL	Total	(kWhrs)	(\$ / yr)		
K-13	35%	590	411	1001	3,866	\$365	\$2,750	
	50%	590	928	1518	5,478	\$518		
	65%	590	1668	2258	7,787	\$736		
	100%	590	4445	5035	16,453	\$1,555		
Harmony-1E	35%	345	165	510	2,025	\$191	\$3,530	4.5 yrs
	50%	345	373	718	2,674	\$253		2.9 yrs
	65%	345	671	1016	3,606	\$341		2.0 yrs
	100%	345	1794	2139	7,109	\$672		0.9 yrs

Table 1: HMT energy savings and payback estimate comparing a 75 kVA HMT to a K-13 transformer in a typical office environment with a high concentration of computer equipment

$$Annual\ Consumption = (Total\ losses\ in\ kW) \times (hrs/day) \times (days/yr) + (NL\ loss\ in\ kW) \times (24 - hrs/day) \times (365 - days/yr)$$

$$$/yr\ Savings = (H1E\ Annual\ Consumption - K13\ Annual\ Consumption) \times 1.35 \times (rate\ in\ $/kWhr)$$

Transformer	% Load	Losses (Watts)			Annual Consumption		Transformer Cost (Est.)	Payback on HMT Premium
		NLL	LL	Total	(kWhrs)	(\$ / yr)		
K-13	35%	590	367	957	8,381	\$792	\$2,750	
	50%	590	835	1425	12,482	\$1,180		
	65%	590	1508	2098	18,381	\$1,737		
	100%	590	4054	4644	40,681	\$3,844		
Harmony-1E	35%	345	164	509	4,458	\$421	\$3,530	2.1 yrs
	50%	345	374	719	6,302	\$596		1.3 yrs
	65%	345	678	1023	8,958	\$847		0.9 yrs
	100%	345	1827	2172	19,024	\$1,798		0.4 yrs

Table 2: HMT energy savings and payback estimate comparing a 75 kVA HMT to a K-13 transformer in a typical Broadcasting Facility or Data Center

Summary

In summary, the inherent ability of Harmonic Mitigating Transformers to cancel harmonic currents within their windings can result in quantifiable energy savings when compared with the losses that would exist if conventional or K-rated transformers were used. If we consider the average premium cost of an HMT over a K-13 transformer, the typical payback in energy savings is 1 to 4 years when loading is expected to be in the 50% to 65% range. This, in itself, can be justification for the use of HMT's but when consideration is also given to the power quality improvement they provide by eliminating voltage distortion in the form of flat-topping, their use becomes even more easily justified.

For the most optimal energy efficiency design, Mirus' Energy Star compliant Harmony-1E™ HMT meets NEMA TP-1 minimum efficiencies at not only 35% load but also across the entire operating range from 35% to 65%. In this manner, energy savings can be assured not only at lightly loaded conditions but also at more

heavily loaded conditions whether the loads are harmonic generating non-linear in nature or simply linear.

References:

1. CEE Update, *News for Stakeholders in CEE's High-Efficiency C&I Transformer Initiative*, March 2002
2. NEMA TP 1-2002, *Guide for Determining Energy Efficiency for Distribution Transformers*, National Electrical Manufacturers Association, p 1
3. N. Mohan, T. Undeland, W. Robbins, *Power Electronics - Convertors, Applications and Design*, John Wiley & Sons Inc., New York, 1995, pp 748-754
4. T.S. Key, J.S La, *Costs and Benefits of Harmonic Current Reduction for Switch-Mode Power Supplies in Commercial Office Building*, IEEE Transactions on Industry Applications, Vol. 32, No. 5 Sept/Oct 1996, pp. 1017-1024
5. ANSI/IEEE C57.110-1986, *Recommended Practice for Establishing Transformer Capability When Supplying Nonsinusoidal Load Currents*, American National Standards Institute



MIRUS Harmony™ Series Transformer Cost Benefit Analysis - 112.5 kVA Harmony-2™

Harmonic distortion in electrical distribution systems caused by high densities of non-linear loads (such as personal computers and other electronic equipment) can create a number of overheating problems as well as many power quality related problems. These include:

- *Overheating of electrical equipment including neutral conductors and transformers*
- *Motor and PF capacitor failures*
- *False tripping of circuit breakers*
- *Premature hardware component failure*
- *Computer 'hangs' and other equipment operational malfunctions*
- *Increased equipment downtime*

Some of the harmonic distortion issues can be addressed by doubling the neutral conductor and specifying K-rated transformers. Although this approach should prevent the transformer and neutral conductor from overheating, it offers absolutely no treatment for the power quality related harmonic problems. In fact, it is possible that widespread use of K-rated transformers will indirectly **contribute** to the power quality problem. K-rated transformers, although capable of withstanding harmonic induced overheating, perform about the same as conventional delta-wye transformers with respect to the voltage distortion that they create. Typically a K-rated or conventional transformer will have more than 5% output voltage distortion when non-linear loading is greater than 50% of the transformers rated load. It is unlikely that more load would be added to a conventional transformer because it would be very hot even at half load. However, the cooler operating temperature of a K-rated transformer would encourage further loading and could raise voltage distortion to unacceptable levels.

MIRUS Harmony™ Series transformers have proven to be very effective in resolving **both** the overheating and the power quality problems related to harmonics. By canceling the harmonic fluxes within its windings, a Harmony™ transformer will maintain very low voltage distortion at its output even under heavy non-linear loading conditions. To demonstrate this advantage, modeling calculations have been prepared which compare a 112.5 kVA, K13 transformer with Harmony-1™ and Harmony-2™ transformers of the same rating. (See MIRUS document titled, 'Modeling the Non-linear Load Contributions to Voltage Distortion at the Output of Three Different Types of 112.5 kVA Transformers'). Voltage distortion at the output of the MIRUS Harmony™ Series transformers are substantially lower than at the K13 transformer under similar non-linear loading conditions. For example, fully loading the K13 transformer with a K factor load of 6.3 resulted in nearly 10% voltage distortion at the transformers output - well above the 5% maximum recommended by IEEE Std 519. Under the same loading, voltage distortion at the output of the Harmony-2™ transformer was only 3.5%.

Benefits of Using Harmony™ Series Transformers

The benefits of using a Harmony™ transformer when servicing non-linear loads are many. By treating the harmonic currents within its secondary windings, the Harmony™ transformer reduces both overheating and voltage distortion. Since it is high voltage distortion that leads to most of the power quality problems listed above, the Harmony™'s ability to reduce voltage distortion will eliminate these problems. Cost benefits can include reduced repairs and equipment replacement, less production downtime and damaged product, improved computer availability and many more. The elimination of the potentially huge cost impacts of these problems would easily justify the use of Harmony™ transformers. These costs are often difficult to quantify however, so an alternate approach is suggested - **costing based on Usable kVA**. In this approach it is assumed that one of the design criteria is to maintain voltage distortion at less than 5% as defined in IEEE Std 519 - Recommended Practices and Requirements for Harmonic Control in Electrical Power Systems.

Costing based on Usable kVA

Modeling has shown that keeping voltage distortion at less than 5% for a 112.5 kVA K13 transformer requires that its non-linear load be less than 50% of its full load rating. On the other hand, voltage distortion at the output of a Harmony-2™ will remain less than 5% even under fully loaded conditions. This means that the **Usable** rating of the K13 transformer is less than 60 kVA. Therefore it would take two 112.5 kVA transformers with associated distribution equipment to service a full 112.5 kVA of non-linear load. The following calculations show how the cost per Usable kVA favors the Harmony-2™ transformer. (Cost estimates include material and labour.)

Scenario 1: 112.5 kVA, 480-208/120V K13 transformer being fed from a 175A, 35kA circuit breaker and servicing 4 x 225A panelboards

112.5 kVA, K13 Transformer.....	\$ 4,500
175A, 35kA, 3-pole CB.....	\$ 1,500
400A, splitter and CB's.....	\$ 900
4 x 225A panelboards	\$ 2,600
Wire and conduit.....	\$ 3,500
TOTAL.....	\$13,000

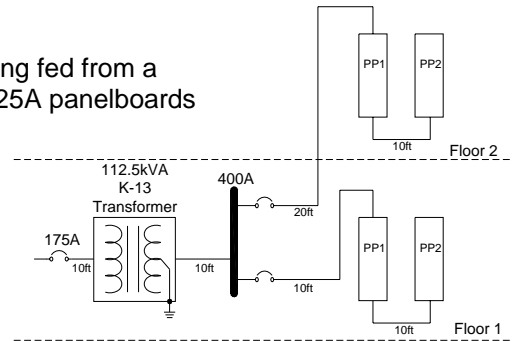

Since the Usable kVA for the K13 transformer is only 60 kVA, installed cost is **\$217 per Usable kVA**

Scenario 2: 112.5 kVA, 480-208/120V Harmony-2™ transformer with two 60% rated (67.5 kVA) secondary windings being fed from a 175A, 35kA circuit breaker and servicing 2 x 225 A panelboards on each output

112.5 kVA, Harmony-2™ Transformer...	\$10,300
175A, 35kA, 3-pole CB.....	\$ 1,500
2 x 225A panelboards c/w main CB.....	\$ 1,800
2 x 225A panelboards.....	\$ 1,300
Wire and conduit.....	\$ 3,500
TOTAL.....	\$18,400

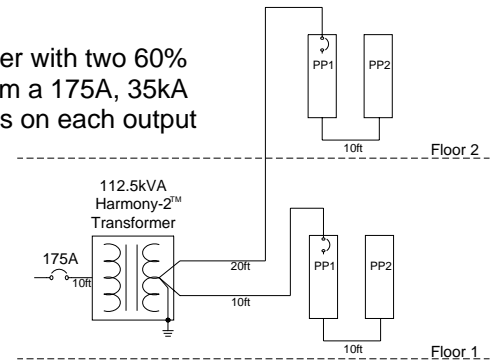

Since the Usable kVA for the Harmony-2™ transformer is the full 112.5 kVA, installed cost is **\$164 per Usable kVA**

Summary

Areas with heavy concentrations of non-linear loads are very vulnerable to both power quality and overheating harmonic problems. K-rated transformers address only the overheating problem. Harmony™ Series transformers treat both sets of problems.

If the Usable kVA value is considered when designing an electrical distribution for non-linear loads, the advantages of using a Harmony™ Series transformer become clear. In the analysis above, the distribution system using the k-rated transformer cost about 30% less than with the Harmony-2™. However, the available capacity is only 50% of the rated capacity, when maintaining less than 5% voltage distortion is established as one of the power quality design criteria. In essence, this means that the Harmony-2™ solution is actually cheaper than the k-rated solution since servicing a fully rated 112.5 kVA load would require a second k-rated transformer and all of its associated distribution equipment.



Modeling the Non-linear Load Contributions to Voltage Distortion at the Output of Three Different Types of 112.5 kVA Transformers

The harmonic currents generated by non-linear loads will produce voltage distortion as they interact with the impedance of an electrical distribution system. This voltage distortion can easily reach unacceptable levels unless Harmonic Mitigating Transformers (HMT) are used to produce cancellation of the offending harmonic currents. In the tables below, output voltage distortion has been calculated for 3 different types of transformers (K13, MIRUS Harmony-1™ and the dual output MIRUS Harmony-2™) under varying load conditions. They clearly show how K-rating alone is insufficient for treating non-linear load generated harmonics.

112.5 kVA, K13 Transformer						Voltage Distortion at Transformer Output, V_h (%rms) ³					
480-120/208V						100% non-linear load			50% non / 50% linear load		
h	Seq.	I_h (%) ¹	I_h (%rms)	X_{Th} (%) ⁴	X_{Sh} (%) ²	Full load	75% load	50% load	Full load	75% load	50% load
1	+ve	100.0	77.5	3.5	0.7	n/a	n/a	n/a	n/a	n/a	n/a
3	zero ⁹	70.0	54.3	10.5	0.0	5.70	4.27	2.85	2.85	2.14	1.42
5	-ve	35.0	27.1	17.5	3.5	5.70	4.27	2.85	2.85	2.14	1.42
7	+ve	20.0	15.5	24.5	4.9	4.56	3.42	2.28	2.28	1.71	1.14
9	zero	10.0	7.8	31.5	0.0	2.44	1.83	1.22	1.22	0.92	0.61
11	-ve	3.0	2.3	38.5	7.7	1.07	0.81	0.54	0.54	0.40	0.27
13	+ve	2.0	1.6	45.5	9.1	0.85	0.63	0.42	0.42	0.32	0.21
15	zero	1.0	0.8	52.5	0.0	0.41	0.31	0.20	0.20	0.15	0.10
K factor =		6.3				³ V_{THD} =			9.7%		
⁶ I_{THD} =		81%							7.3%		
									4.8%		
									4.8%		
									3.6%		
									2.4%		

112.5 kVA, Harmony-1™ Transformer						Voltage Distortion at Transformer Output, V_h (%rms)					
480-120/208V						100% non-linear load			50% non / 50% linear load		
h	Seq.	I_h (%)	I_h (%rms)	X_{Th} (%)	X_{Sh} (%)	Full load	75% load	50% load	Full load	75% load	50% load
1	+ve	100.0	77.5	3.5	0.7	n/a	n/a	n/a	n/a	n/a	n/a
3	zero ¹⁰	70.0	54.3	1.1	0.0	0.57	0.43	0.28	0.28	0.21	0.14
5	-ve	35.0	27.1	17.5	3.5	4.94	3.70	2.47	2.47	1.85	1.23
7	+ve	20.0	15.5	24.5	4.9	3.95	2.96	1.98	1.98	1.48	0.99
9	zero	10.0	7.8	3.2	0.0	0.24	0.18	0.12	0.12	0.09	0.06
11	-ve	3.0	2.3	38.5	7.7	1.07	0.81	0.54	0.54	0.40	0.27
13	+ve	2.0	1.6	45.5	9.1	0.85	0.63	0.42	0.42	0.32	0.21
15	zero	1.0	0.8	5.3	0.0	0.04	0.03	0.02	0.02	0.02	0.01
K factor =		6.3				V_{THD} =			6.5%		
I_{THD} =		81%							4.9%		
									3.2%		
									3.2%		
									2.4%		
									1.6%		

112.5 kVA, Harmony-2™ Transformer						Voltage Distortion at Transformer Output, V_h (%rms)					
480-120/208V						100% non-linear load			50% non / 50% linear load		
h	Seq.	I_h (%)	I_h (%rms)	X_{Th} (%)	X_{Sh} (%)	Full load	75% load	50% load	Full load	75% load	50% load
1	+ve	100.0	77.5	3.5	0.7	3.26	2.44	1.63	1.63	1.22	0.81
3	zero ¹⁰	70.0	54.3	1.1	0.0	0.57	0.43	0.28	0.28	0.21	0.14
5	-ve	35.0	27.1	17.5	3.5	2.56	1.92	1.28	1.28	0.96	0.64
7	+ve	20.0	15.5	24.5	4.9	2.05	1.54	1.03	1.03	0.77	0.51
9	zero	10.0	7.8	3.2	0.0	0.24	0.18	0.12	0.12	0.09	0.06
11	-ve	3.0	2.3	38.5	7.7	0.93	0.70	0.47	0.47	0.35	0.23
13	+ve	2.0	1.6	45.5	9.1	0.73	0.55	0.37	0.37	0.28	0.18
15	zero	1.0	0.8	5.3	0.0	0.04	0.03	0.02	0.02	0.02	0.01
K factor =		6.3				V_{THD} =			3.5%		
I_{THD} =		81%							2.7%		
									1.8%		
									1.8%		
									1.3%		
									0.9%		

(For Notes and Assumptions see p. 2)

Notes and Assumptions:

1. The load harmonic spectrum used is that of a typical 120V, 1-ph., switch-mode power supply. Examples of such loads include personal computers, monitors, telecommunications and broadcasting equipment.

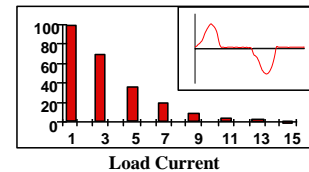

2. Each 112.5 kVA transformer is fed by a distortionless 3-ph., 480V source through a system source impedance $Z_{Sh} = jX_{Sh} = j0.007pu$ (based on a 20kA fault level at transformer primary). X_{Sh} , the upstream supply reactance, does not enter into the calculations for voltage drop at 3rd, 9th, and 15th harmonics because the balanced portion of these currents (called the triplens) are either trapped in the delta primary, as in the K-factor transformer, or treated in the secondary windings, as in the Harmony™ transformers.

3. Voltage distortion calculation is as follows:

$$V_h(\% rms) = \frac{I_h(\% rms) \times [X_{Th}(\%) + X_{Sh}(\%)]}{100}$$

$$V_{THD} = \sqrt{V_{3(\% rms)}^2 + V_{5(\% rms)}^2 + \dots + V_{15(\% rms)}^2}$$

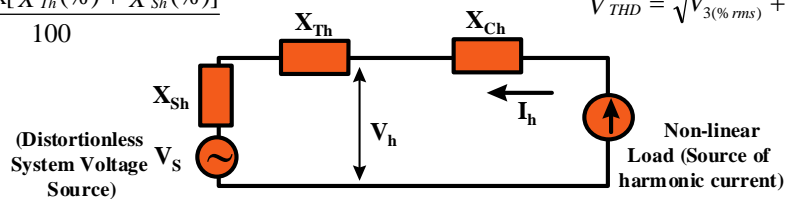

Where,

- $V_h(\% rms)$ = Voltage distortion, line-to-neutral, at harmonic h in %rms
- $I_h(\% rms)$ = Current at harmonic h in %rms
- $X_{Th}(\%)$ = Transformer reactance at harmonic h in %
- $X_{Sh}(\%)$ = Upstream system reactance at harmonic h in %
- $X_{Ch}(\%)$ = Downstream cable reactance at harmonic h in %
- $V_{THD}(\%)$ = Voltage total harmonic distortion in %.

4. 112.5 kVA transformer reactances used are as follows (resistance is considered negligible):

- K-13: $X^+ = X^- = X^0 = 3.5\%$
- H-1: $X^+ = X^- = 3.5\%$, $X^0 = 0.35\%$
- H-2: $X^+ = X^- = 3.5\%$, $X^0 = 0.35\%$

5. Voltage distortion at the output of a transformer will vary with respect to the following:

- a. System source impedance
- b. Transformer impedance
- c. Non-linear load harmonic spectrum
- d. % of linear vs non-linear load

6. Total Harmonic Current Distortion, I_{THD} , is calculated as follows:

$$I_{THD} = \sqrt{I_3^2(\% rms) + I_5^2(\% rms) + \dots + I_{15}^2(\% rms)}$$

7. K factor is calculated as follows: $K_{factor} = \sum_{h=1}^{h=15} h^2 I_h^2$

Where, I_h = rms current at harmonic h, in per unit of rated rms load current

8. In the Harmony-2™ transformer, 5th and 7th load current harmonic fluxes cancel on the secondary side to reduce the voltage distortion at the 5th and 7th harmonics. For calculation purposes, it is assumed that unbalanced load currents leave a 20% residual and that half of the transformer impedance is on the primary side. For the Harmony-1™, it is assumed that pairs of Harmony-1™ transformers with 0° and 30° phase shifts are used to reduce the 5th and 7th harmonic voltage distortion by canceling these currents on the primary bus. Again, a 20% residual is used in the calculations.

9. Triplen harmonic voltage distortion is substantially lower in the Harmony™ transformers because they are designed to cancel the balanced portion of the triplen harmonic fluxes in their secondary windings.

10. Voltage distortion will be even higher at the loads due to the effect of downstream cable impedance. Also, distortion will be higher when sources, such as Diesel Generators or UPS units, are used, because of their high internal impedance.