



415V DISTRIBUTION FOR GREEN DATA CENTERS

Prepared by: Anthony (Tony) Hoevenaars, P. Eng
President and CEO
Mirus International Inc.

ABSTRACT

In an effort to reduce energy consumption in N. American Data Centers, electrical engineers have begun to incorporate 230/400V or 240/415V distribution into their designs. Although these are very common voltages in Europe and elsewhere around the world, USA and Canadian power distribution has been designed around 120/208V systems. By moving to the higher voltage, both energy and infrastructure savings can be realized as computer power supplies will operate at higher efficiencies and the step-down isolation transformers can be eliminated.

There are, of course, areas that need to be addressed when designing for 400V or 415V distribution in N. America. If a 400V European designed UPS is to be used, it must be approved by UL or another N. American certified electrical testing agency. Circuit breakers, panelboards and other electrical equipment must be rated for the higher voltage. The system must be designed to ensure that there will not be multiple return paths for phase-to-neutral ground faults. And consideration needs to be given to the effects of harmonics when larger computer loads are connected 240V phase-to-neutral rather than 208V phase-to-phase. But when properly designed, energy reductions of 5% or higher and power system infrastructure savings are easily attainable making this approach well worth consideration.

INTRODUCTION

With the ever increasing power densities of today's computer equipment, Data Center energy consumption has grown rapidly in recent years. In 2006, computers in the USA consumed 61 billion kWh at a cost of \$4.5 billion. This had more than doubled since 2000 and was a full 1.5% of the total electrical consumption in the USA¹. Average Data Center power consumption grew from 2.1 kW per server rack in 1992 to 14 kW per rack in 2006. Some estimates predict that Data Center electrical requirements will further double by 2011¹.

With this considerable amount of electrical consumption, there is surely opportunity for significant energy savings. Recently, one approach being widely discussed in N. America is the use of 400V or 415V distribution to the server racks in Data Centers. Since computer equipment is designed to be sold worldwide, their power supplies are capable of operating over a wide voltage range (typically 100V to 240V). When operating at higher voltages, these computer power supplies produce lower internal losses and therefore, run much more efficiently. Since 400V or 415V distribution is very common in Europe, it can be readily deployed in N. America and therefore, is expected to become widely used in the coming years².

Additionally, of course, any reduction in energy consumption comes with substantial benefits for the environment.

ADVANTAGES OF 415V DISTRIBUTION OVER 208V

The principle reason for considering 240/415V power distribution instead of 120/208V is the energy efficiency improvement. Although designed to operate over a wide range of voltages, computer power supplies are most efficient when operating at their highest voltage rating. Table 1 shows the specifications of a typical server power supply. At 240V, the power supply operates at 85.5% efficiency. But at 120V, it operates at only 82% efficiency – a full 3.5% drop. Comparing 208V with 240V, the efficiency drop is 1.5%. Energy is saved in both the direct reduction of electricity consumed and the reduced load on the cooling system which is typically in the range of 40% to 50% of the kW reduction.

Power Supply Specification						
Operational Input Voltage Range (Vrms)	90 to 264					
Frequency Range (Nominal) (Hz)	47 to 63 (50/60)					
Nominal Input Voltage (Vrms)	100	120	208	220	230	240
Max Rated Output Wattage Rating	800	850	1000	1000	1000	1000
Nominal Input Current (A rms)	10.0	8.8	5.85	5.5	5.2	4.97
Max Rated Input Wattage Rating (Watts)	980	1035	1193	1186	1172	1169
Max. Rated VA (Volt-Amp)	1000	1056	1217	1210	1196	1193
Efficiency (%)	81.5	82	84	84	85	85.5
Power Factor	0.98	0.98	0.98	0.98	0.98	0.98
Leakage Current (mA)	0.44	0.52	0.91	0.96	1.00	1.04
Max. Inrush Current (A peak)	30	30	30	30	30	30
Max. Inrush Current duration (mS)	3	3	3	3	3	3

Table 1: Specifications for an HP ProLiant DL380 G5 power supply³

Additional energy savings are achieved by the elimination of the isolation transformer used to step-down voltage from 480V to 208V. Transformer efficiencies vary with the load but can also vary quite substantially from one manufacturer to the next. In general, efficiency gains of 2 to 3% are easily achievable by the elimination of the PDU transformer.

There are also benefits other than the energy savings. With the higher voltage, more power can be delivered to the racks with less current. This provides savings in the number of drops required to service the racks and/or the size of the conductors used for these drops. Table 2 provides a comparison of 208V Ph-Ph, 120V Ph-N and 240V Ph-N configurations.

As can be seen, a 30A circuit at 240V distribution provides more power to the rack than 120V or 208V. The 240V distribution requires only 1 drop or 2 drops with redundancy and requires only 1-pole breakers.

Configuration	208V, Ph-Ph	120V, Ph-N	240V, Ph-N
			
Circuit Amps	30	30	30
3-Ph Continuous Power (kW)	$208V \times 30A \times \sqrt{3} \times 0.8 = 8.6$	$120V \times 30A \times 3 \times 0.8 = 8.6$	$240V \times 30A \times 3 \times 0.8 = 17.3$
Rack kW	15	15	15
# of Drops	2	2	1
With Redundancy	4	4	2

Table 2: Comparison of electrical drops required for server racks at various voltage configurations

415V DISTRIBUTION AND HARMONIC DISTORTION

Several years ago, harmonic distortion became a very serious issue in Data Centers and other areas where high concentrations of computer equipment were in use. This was due to the fact that the computer power supplies consumed current in non-sinusoidal pulses which contained high levels of current harmonics. These current harmonics were distorting the supply voltage and causing overheating in the electrical distribution and particularly, transformers and neutral conductors.

Many practices were adopted to address this issue including doubling of the neutral conductors and using K-Rated or, better yet, Harmonic Mitigating Transformers. The problem was even more severe in Europe because the neutral in 400V distribution systems are carried much further upstream to the Utility system. As a result, IEC in Europe introduced mandatory standards (IEC 61000-3-2⁴) that limited the allowable levels of harmonics introduced by computers and other power electronic devices. Power supplies designed to these standards became known as 'Power Factor Corrected' because by reducing the reactive power of the harmonics, the true power factor of the power supply was improved.

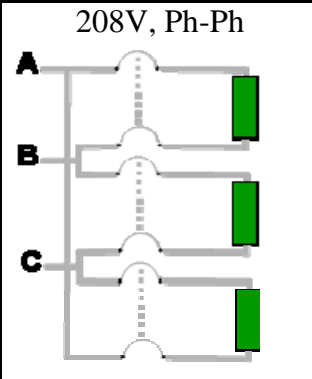
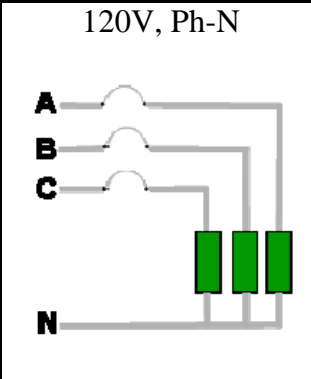
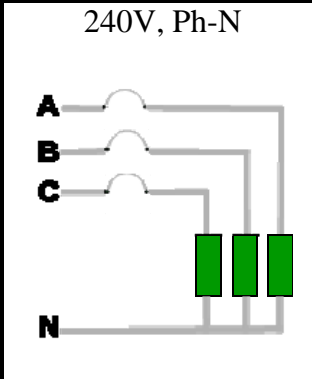
In order to sell their computers globally, manufacturers began to use PF Corrected power supplies in many of their products. Certainly, the higher powered computer servers incorporated them. This helped reduce the harmonic problem in Data Centers but the issue still remains because, although the IEC standards required lower levels of harmonics, they did not require perfectly sinusoidal current waveforms. Table 3 shows the harmonic current levels of a 500W to 850W power supply that meets the IEC standard but still draws 3rd harmonic current at 45% of the fundamental current when operating at 50% load.

Load	100%	90%	80%	70%	60%	50%	40%	30%	20%	10%
P.F.	0.89	0.884	0.878	0.871	0.861	0.851	0.842	0.833	0.818	0.818
THD%	37.738	39.413	41.518	44.337	47.267	50.743	53.79	56.305	56.111	55.14
Irms	3.703	3.343	2.995	2.634	2.29	1.946	1.597	1.241	0.876	0.541
Harm-1	3.465	3.111	2.768	2.413	2.07	1.736	1.407	1.081	0.763	0.475
Harm-3	1.21	1.126	1.046	0.965	0.88	0.787	0.68	0.551	0.396	0.24
Harm-5	0.399	0.393	0.386	0.379	0.351	0.32	0.278	0.225	0.148	0.081
Harm-7	0.185	0.182	0.173	0.165	0.151	0.137	0.145	0.105	0.056	0.037
Harm-9	0.136	0.131	0.127	0.121	0.114	0.107	0.073	0.058	0.018	0.013
Harm-11	0.087	0.072	0.074	0.071	0.067	0.063	0.044	0.02	0.005	0.009
Harm-13	0.063	0.069	0.064	0.061	0.058	0.055	0.025	0.015	0.008	0.003
Harm-15	0.047	0.042	0.051	0.048	0.045	0.042	0.028	0.009	0.004	0.002
Harm-17	0.053	0.044	0.039	0.041	0.038	0.035	0.016	0.01	0.004	0.003
Harm-19	0.035	0.041	0.038	0.035	0.032	0.029	0.013	0.013	0.005	0.003
Harm-21	0.057	0.036	0.026	0.028	0.025	0.022	0.015	0.016	0.003	0.005
Harm-23	0.045	0.051	0.028	0.016	0.025	0.02	0.015	0.014	0	0.003
Harm-25	0.052	0.032	0.032	0.018	0.03	0.024	0.016	0.011	0.005	0.002
Harm-27	0.036	0.046	0.031	0.022	0.018	0.029	0.011	0.007	0.005	0.001
Harm-29	0.033	0.036	0.045	0.015	0.02	0.025	0.01	0.006	0.005	0.003
Harm-31	0.016	0.04	0.033	0.02	0.013	0.023	0.015	0.01	0.004	0.002

**$I_3 = 45\%$ of
Fundamental**

Table 3: 500W to 850W Computer Power Supply that meets IEC 61000-3-2

What also contributed to the reduced concern about harmonics in Data Centers was the move towards 208V supply for the larger servers. For 120V supply, only one phase conductor and return neutral are required. To provide 208V however, two phase conductors are used which eliminates the neutral return path for the 3rd harmonic current. With no return path, 3rd harmonic is much less of a problem. With 400V or 415V distribution though, these larger server power supplies will once again be supplied by one phase conductor and return neutral. If 3rd harmonic is as high as 45% of the fundamental current, neutrals can once again be

overloaded unless some form of harmonic mitigation is applied. Fortunately, we now know a lot more about how to deal with harmonics so this does not need to be an issue that prevents implementation of 415V distribution.

CONVENTIONAL DATA CENTER DESIGN IN N. AMERICA

Figure 1 shows a very simplified 1-Line diagram for a typical Data Center in the USA. More complex Data Centers would involve back-up power generation (diesel generators, microturbines, etc.), redundant UPS systems, dual redundant supplies, static or mechanical transfer switches, busway distribution, etc., but the applied voltages used are standard.

The building's incoming electrical service is typically 277/480V, 3-ph, 3 or 4-wire. UPS systems used for back-up power are normally 480V, 3-ph, 3-wire (no neutral). Electrical supply to the server racks is typically 120/208V, 3-ph, 4-wire. Power Distribution Units (PDU's) with delta-wye isolation transformers are used to transform voltage from 480V to 120/208V.

This configuration has served the industry well for many years but certain inefficiencies are now being highlighted when compared with standard European systems. These include:

1. Computer equipment fed by 120V or 208V operates less efficiently than when fed from 230V or 240V.
2. Eliminating the PDU isolation transformer would save both its losses and purchase price.

There are some inherent advantages however, that will be lost with the elimination of the isolation transformer. They include:

1. Creation of a separately derived neutral at the wye secondary
2. Trapping of 3rd harmonic and other triplen harmonic currents within the primary delta winding
3. No need for neutral conductor upstream of the transformer

It is wise for any Data Center design engineer to address these issues before implementing a 415V distribution design.

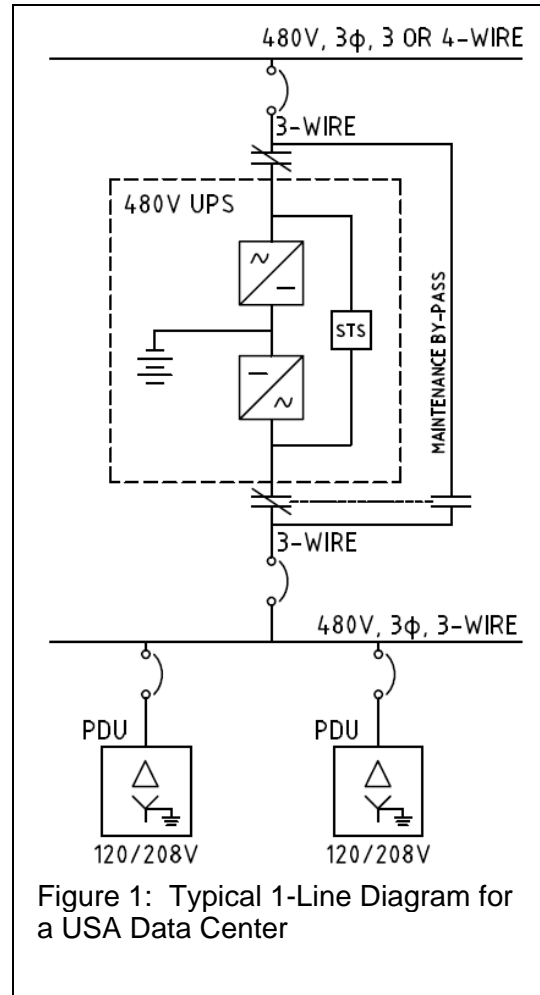

Figure 1: Typical 1-Line Diagram for a USA Data Center

APPLYING EUROPEAN DATA CENTER DESIGN IN N. AMERICA

Figure 2 shows the 1-Line diagram for a typical European Data Center design applied in N. America. A standard 400V UPS unit is shown. Although approved for use in Europe, this UPS would need to be certified by UL or another N. American certified electrical testing agency which would certainly limit the selection of UPS supplier.

Also, an input isolation transformer is required to transform voltage from 480V to 400V. An autotransformer is not suitable for this application because it would not provide suitable isolation between the upstream neutral on the 480V system and the downstream neutral on the 415V system. Without this isolation, two ground return paths would be created during a phase-to-ground fault when the UPS is operating in by-pass mode.

In addition, a neutral conductor must be run from the 400V side of the transformer to the server racks. As mentioned earlier, even with PF Corrected power supplies, there might be a requirement for the neutral to be a higher ampacity than the phase conductors due to 3rd and other triplen harmonic currents.

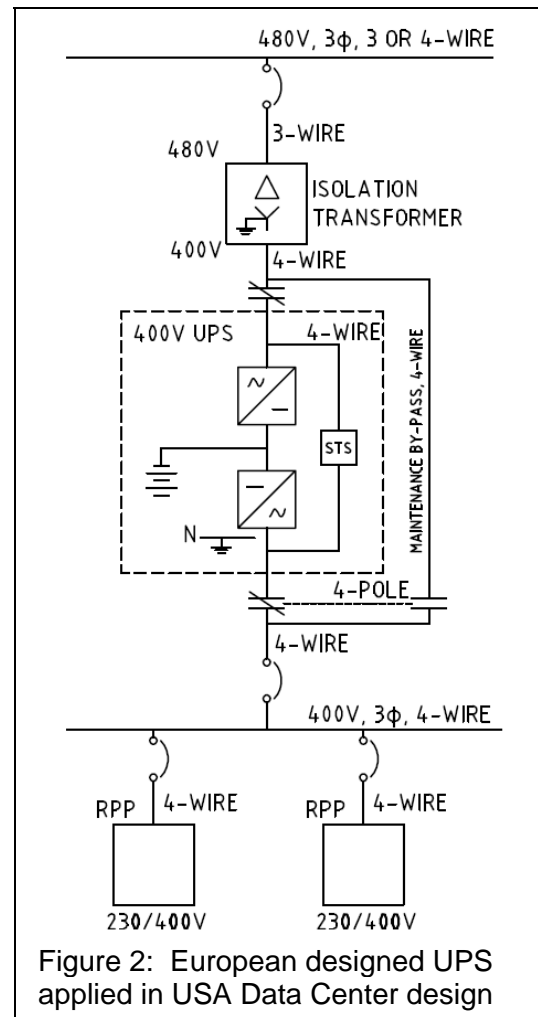

Figure 2: European designed UPS applied in USA Data Center design

415V DISTRIBUTION USING HARMONIC MITIGATING REMOTE POWERPANEL

A better way of achieving 415V distribution in N. American Data Centers is to use standard 480V UPS systems and do the 480V to 415V transformation near the server racks (see Figure 3). If the autotransformer used for this transformation also provides harmonic mitigation and a low zero sequence path for return neutral current and ground faults, all considerations for adopting 415V in N. America, as described in this paper, are addressed.

Mirus offers a very unique Harmonic Mitigating Remote Panelboard (HMRP) that meets this challenge. It comes equipped with a combined step-down and harmonic mitigating autotransformer built-in. This provides 480V to 415V conversion while treating the 3rd, 5th, 7th and 9th harmonic currents generated by the computer equipment. The unique zigzag configuration of this autotransformer also provides a low impedance zero sequence path for return neutral current and phase-to-neutral fault currents. This allows the system neutral to be grounded in only one location with operation either on UPS power or in by-pass mode. Figure 3 shows a configuration where the neutral is grounded at an isolation transformer inserted in the by-pass circuit. This neutral is carried through to the neutral at the HMRP autotransformer.

Current in a phase-to-ground fault will return through the ground and back to the phase conductor through the zigzag connection of the autotransformer regardless of whether the loads are fed from the UPS or another source through its by-pass. This allows the use of either a 3-phase, 3-wire or 4-wire UPS.

3rd and other triplen harmonics are treated by providing an alternate path through the zigzag connection. Mirus pioneered this approach and it has been used very effectively for reduction of neutral current due to harmonics for nearly 20 years. 5th and 7th order harmonics are cancelled through phase shifting strategies built into the purely electro-magnetic filter.

Standard UL certified 480V panelboards and circuit breakers are used to meet the 415V requirement.

If 120/208V power is required for some loads, standard PDU's with isolation transformers can be used or smaller stepdown isolation transformers downstream of the HMRP. Also, in existing Data Centers, 415V distribution can be easily introduced with any expansion by simply incorporating HMRP's instead of conventional PDU's.

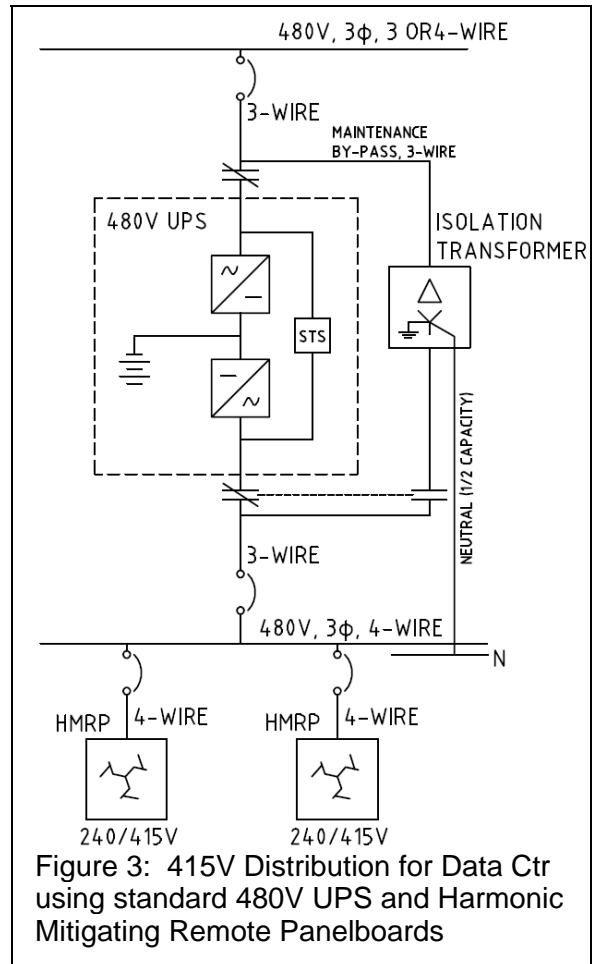

Figure 3: 415V Distribution for Data Ctr using standard 480V UPS and Harmonic Mitigating Remote Panelboards

CONCLUSION AND SUMMARY

In addition to the improved operating efficiencies, 415V distribution can provide an opportunity to reduce electrical infrastructure costs. As mentioned earlier, PDU isolation transformers are eliminated and electrical drops to server racks can be reduced. However, when European designed 400V UPS systems are employed some of this infrastructure benefit is offset by other requirements, such as:

1. The need for a step-down isolation transformer at the UPS input to lower voltage and prevent multiple neutral grounds while in UPS by-pass mode.
2. The need for larger 3-phase conductors between the UPS and PDU's due to the lower voltage (400V vs 480V). Larger switchboards and circuit breakers might also be required.
3. The need for neutral conductors between the UPS and PDU's. These also might need to be oversized due to 3rd and other triplen harmonic currents.

These additional requirements are not necessary when using the 480-415V HMRP because the voltage transformation is done near the loads and standard 480V UPS systems can be used.

A comparison of the 3 Options is presented in Table 4. When all design criteria is taken into consideration, 415V Distribution with standard 480V UPS systems and 480-415V HMRP's clearly provides the most benefit.

Comparison of Benefits	Mirus 415V HMRP	480V with PDU	400V UPS	Comments
Compatible with standard 480V UPS	✓	✓		Few 400V designs are UL certified so selection is limited
No additional UPS input transformer	✓	✓		Required for 400V UPS
No isolation transformer in PDU	✓		✓	480-120/208V required for 480V with PDU
No or reduced neutral between UPS, switchboard and PDU or HMRP	✓	✓		400V UPS must be 4-wire. HMRP needs ½ capacity neutral
Conductor sizes reduced downstream of UPS	✓	✓		400V requires higher current for same kW than 480V
Lower amp rating of switchboard and CB's at UPS output	✓	✓		400V requires higher current for same kW than 480V
Fewer # of drops or smaller cable sizes to racks	✓		✓	120/208V requires larger drops than 230/400V or 240/415V
No isolation transformer required in by-pass circuit		✓	✓	HMRP requires isolation trans. for N-to-G bond
Higher efficiency of computer power supplies	✓		✓	Power supplies produce lower losses at higher voltage
Reduced voltage and current distortion	✓			HMRP improves PQ by reducing current and voltage harmonics
Lower harmonic losses in UPS and cables	✓			HMRP further lowers losses by reducing current harmonics

Benefits:

Energy Savings Infrastructure Reduction Power Quality Improvement

Table 4: Comparison of Data Center Distribution Options

References:

- [1] *Report to Congress on Server and Data Center Energy Efficiency, Public Law 109-431*, U.S. Environmental Protection Agency ENERGY STAR Program, Aug. 2007
- [2] *Qualitative Analysis of Power Distribution Configurations for Data Centers*, The Green Grid
- [3] *Power Efficiency Gains by Deploying 415 VAC Power Distribution in North American Data Centers*, Server Technology Inc., White Paper STI-100-008, Mar. 2009
- [4] *Limits for harmonic current emissions (equipment input current < 16A per phase single & 3 phase)*, IEC/EN 61000-3-2 (2000(A14))