

GENERAL SPECIFICATIONS:

PRIMARY

3-phase, 3-wire, 60Hz

THREE SECONDARIES [each]

3-phase, 4-wire, 60Hz, 40% rated

OPERATING TEMPERATURE RISE^[7]

130°C [115°C] [80°C]

INSULATION CLASS^[7]

220°C

ANGULAR DISPLACEMENT^[1]

20° between secondary groups

ZERO SEQUENCE IMPEDANCE

$Z_0 < 0.95\%$, $X_0 < 0.3\%$
(or as per table below)

PRIMARY TAPS

15kVA (and all 208V): $\pm 1 \times 5\%$
30kVA – 300kVA: $\pm 2 \times 2.5\%$

K-FACTOR CAPABILITY

20

CREST FACTOR CAPABILITY

4.5

COMMON NEUTRAL BUS AMPACITY

200% of phase current

FULL LOAD EFFICIENCY

> 97%

MAGNETISING INRUSH

< 10 times FL RMS

WINDING MATERIAL

Copper

INSULATING VARNISH IMPREGNATION

Polyester Resin

AUDIBLE SOUND LEVEL

As per NEMA ST-20

15 - 45kVA: 45dB
75 - 150kVA: 50dB
225 - 300kVA: 55dB

ENCLOSURE

Type: NEMA-3R, ventilated
Paint: Polyester powder coated
Colour: ANSI 61 Grey

ELECTROSTATIC SHIELD

Single, [double]

OPTIONS:

OVER-TEMPERATURE SENSORS

[170°C], [200°C]

SOLID BOTTOM PLATE (Case 'MN' only)

[yes], [no]

'MN' STYLE ENCLOSURE

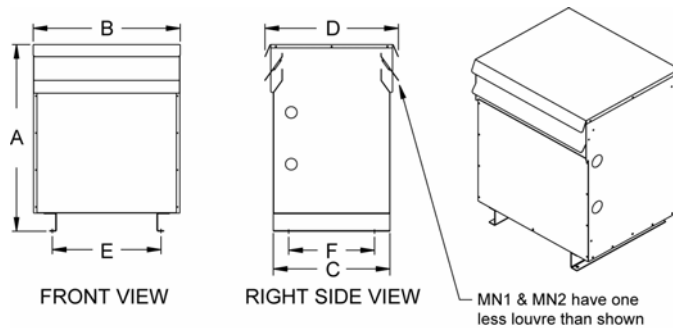

DIMENSIONS - inches [mm]

CASE STYLE	A	B	C	D	E	F
MN1	22.00 [559]	16.75 [425]	15.00 [381]	19.00 [483]	13.75 [349]	13.00 [330]
MN2	29.00 [737]	21.50 [546]	19.50 [495]	23.50 [597]	17.00 [432]	17.50 [445]
MN3	38.00 [965]	26.00 [661]	21.00 [534]	25.00 [635]	21.50 [546]	19.00 [483]
MN4	41.00 [1041]	32.00 [813]	25.50 [648]	29.50 [749]	23.50 [597]	23.50 [597]

'LN' STYLE ENCLOSURE

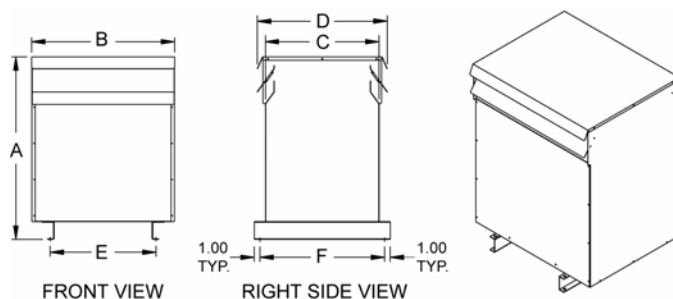

DIMENSIONS - inches [mm]

CASE STYLE	A	B	C	D	E	F
LN1	51.50 [1308]	39.50 [1003]	30.00 [762]	34.00 [864]	24.00 [610]	32.00 [813]
LN2	59.00 [1499]	48.50 [1232]	34.00 [864]	38.00 [965]	27.50 [699]	36.00 [915]
LN3	66.00 [1677]	51.50 [1308]	39.00 [991]	43.00 [1092]	34.00 [864]	41.00 [1042]
LN6	70.00 [1778]	64.00 [1626]	40.00 [1016]	44.00 [1118]	40.00 [1016]	42.00 [1067]

Product Code:

Angular Displacement
20
Secondary L-L Voltage
208, 480, 600
Secondary Rating [each]
40% (of primary kVA)

H3 t - dd - hhh - xxx - kVA - 40% - S

Transformer Type Primary Primary kVA Electrostatic
T = (isolation) L-L Voltage 15, 30, 45, 75, 112.5, Shield: S = (single shield)
A = (autotransformer) 208, 480, 600 150, 225, 300 SS = (double shield)

Sizes			Losses ^[2]		Impedances			Terminal Lugs Provided (Mechanical Type)				
kVA Primary	Case Style	Weight lb [kg] ^[2]	Iron	Copper (full load)	3 Phase Short Circuit ^[5]	Zero Sequence ^[6]		Primary			Each Sec. Phase	Total on Common
						Z ₀	X ₀	208V	480V	600V	120/208V	Neutral
30	MN2	430 [195]	260W	750W	2.8-3.5%	< 0.95%	< 0.3%	2/0-#6	#2-#14	#2-#14	#2-#14	3x2/0-#6
45	MN2	550 [250]	340W	1260W	2.8-3.5%	< 0.95%	< 0.3%	250MCM-#6	#2-#14	#2-#14	2/0-#6	6x2/0-#6
75	MN3	820 [375]	550W	1750W	2.8-3.5%	< 0.95%	< 0.3%	600MCM-#4	2/0-#6	2/0-#6	2/0-#6	6x250MCM-#6
112.5	MN4	1100 [500]	660W	2700W	2.8-3.5%	< 0.95%	< 0.3%	2x350MCM-#6	250MCM-#6	2/0-#6	250MCM-#6	6x250MCM-#6
150	MN4	1400 [635]	750W	3700W	2.8-3.5%	< 0.95%	< 0.3%	2x350MCM-#6	350MCM-#6	250MCM-#6	350MCM-#6	6x350MCM-#6
225	LN1	1950 [885]	900W	5800W	3.2-4.5%	< 1.0%	< 0.5%	2x600MCM-#4	600MCM-#4	600MCM-#4	600MCM-#4	6x600MCM-#4
300	LN2	2600 [1180]	1200W	6800W	3.2-4.5%	< 1.0%	< 0.5%	Copper Pad	Copper Pad	Copper Pad	Copper Pad	Copper Pad

- Primary group H leads the three secondary groups X by 10, 30 and 50 degrees respectively.
- Estimated Values.
- For additional information refer to: Typical Specifications, Technical Guide, Internal Layout and Connection Diagrams.
- Specifications are subject to change without notice.
- Based on primary side kVA rating and measured with all secondaries short circuited.
- Based on kVA rating of one secondary and measured with only one secondary short circuited.
- 15kVA and 30kVA transformers have 200° C insulation class.

