

#### GENERAL SPECIFICATIONS:

##### PRIMARY

3-phase, 3-wire, 60Hz

##### DUAL SECONDARIES [each]

3-phase, 4-wire, 60Hz, 60% rated

##### OPERATING TEMPERATURE RISE<sup>[7]</sup>

130°C [115°C] [80°C]

##### INSULATION CLASS<sup>[7]</sup>

220°C

##### ANGULAR DISPLACEMENT<sup>[1]</sup>

Select 0° or 15° lag

##### ZERO SEQUENCE IMPEDANCE

$Z_0 < 0.95\%$ ,  $X_0 < 0.3\%$   
(or as per table below)

##### PRIMARY TAPS

15kVA (and all 208V):  $\pm 1 \times 5\%$   
30kVA – 500kVA:  $\pm 2 \times 2.5\%$

##### K-FACTOR CAPABILITY

20

##### CREST FACTOR CAPABILITY

4.5

##### COMMON NEUTRAL BUS AMPACITY

200% of phase current

##### FULL LOAD EFFICIENCY

> 97%

##### MAGNETISING INRUSH

< 10 times FL RMS

##### WINDING MATERIAL

Copper

##### INSULATING VARNISH IMPREGNATION

Polyester Resin

##### AUDIBLE SOUND LEVEL

As per NEMA ST-20

15 - 45kVA: 45dB

75 - 150kVA: 50dB

225 - 300kVA: 55dB

500kVA: 60dB

##### ENCLOSURE

Type: NEMA-3R, ventilated

Paint: Polyester powder coated

Colour: ANSI 61 Grey

##### ELECTROSTATIC SHIELD

Single, [double]

#### OPTIONS:

##### OVER-TEMPERATURE SENSORS

[170°C], [200°C]

##### SOLID BOTTOM PLATE (Case 'MN' only)

[yes], [no]

#### 'MN' STYLE ENCLOSURE

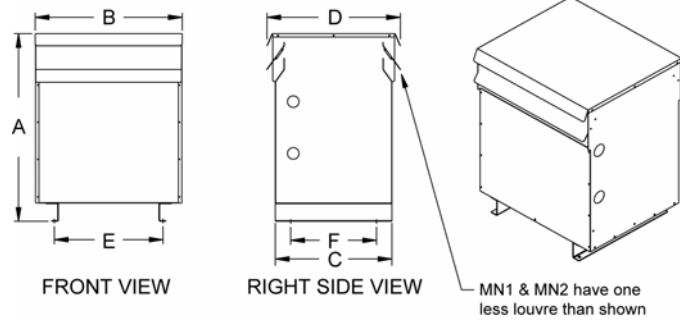

#### DIMENSIONS - inches [mm]

CASE STYLE	A	B	C	D	E	F
MN1	22.00 [559]	16.75 [425]	15.00 [381]	19.00 [483]	13.75 [349]	13.00 [330]
MN2	29.00 [737]	21.50 [546]	19.50 [495]	23.50 [597]	17.00 [432]	17.50 [445]
MN3	38.00 [965]	26.00 [661]	21.00 [534]	25.00 [635]	21.50 [546]	19.00 [483]
MN4	41.00 [1041]	32.00 [813]	25.50 [648]	29.50 [749]	23.50 [597]	23.50 [597]

#### 'LN' STYLE ENCLOSURE

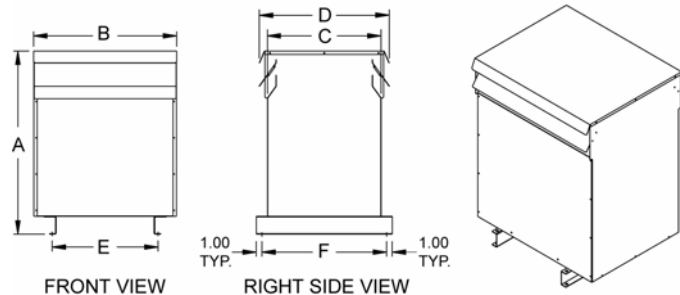

#### DIMENSIONS - inches [mm]

CASE STYLE	A	B	C	D	E	F
LN1	51.50 [1308]	39.50 [1003]	30.00 [762]	34.00 [864]	24.00 [610]	32.00 [813]
LN2	59.00 [1499]	48.50 [1232]	34.00 [864]	38.00 [965]	27.50 [699]	36.00 [915]
LN3	66.00 [1677]	51.50 [1308]	39.00 [991]	43.00 [1092]	34.00 [864]	41.00 [1042]
LN6	70.00 [1778]	64.00 [1626]	40.00 [1016]	44.00 [1118]	40.00 [1016]	42.00 [1067]

#### Product Code:

**H2 t - dd - hhh - xxx - kVA - 60% - S**

Angular Displacement: 00, 15  
Secondary L-L Voltage: 208, 480, 600  
Secondary Rating [each]: 60% (of primary kVA)  
Transformer Type: T = (isolation), A = (autotransformer)  
Primary L-L Voltage: 208, 480, 600  
Primary kVA: 15, 30, 45, 75, 112.5, 150, 225, 300  
Electrostatic Shield: S = (single shield), SS = (double shield)

kVA Primary	Sizes		Losses <sup>[2]</sup>		3 Phase Short Circuit <sup>[5]</sup>	Zero Sequence <sup>[6]</sup>		Terminal Lugs Provided (Mechanical Type)				
	Case Style	Weight lb [kg] <sup>[2]</sup>	Iron	Copper (full load)		Zo	Xo	Primary			Each Sec. Phase 120/208V	Total on Common Neutral
								208V	480V	600V		
15	MN1	250 [115]	230W	280W	2.8-3.5%	< 0.95%	< 0.3%	#2-#14	#2-#14	#2-#14	#2-#14	2x #2-#14
30	MN2	375 [170]	300W	530W	2.8-3.5%	< 0.95%	< 0.3%	2/0-#6	#2-#14	#2-#14	#2-#14	2x2/0-#6
45	MN2	500 [227]	370W	750W	2.8-3.5%	< 0.95%	< 0.3%	250MCM-#6	#2-#14	#2-#14	2/0-#6	2x250MCM-#6
75	MN3	750 [340]	540W	1450W	2.8-3.5%	< 0.95%	< 0.3%	600MCM-#4	2/0-#6	2/0-#6	250MCM-#6	4x350MCM-#6
112.5	MN4	1000 [455]	700W	2300W	2.8-3.5%	< 0.95%	< 0.3%	2x350MCM-#6	250MCM-#6	2/0-#6	350MCM-#6	4x350MCM-#6
150	MN4	1300 [590]	850W	2900W	3.2-4.5%	< 0.95%	< 0.3%	2x350MCM-#6	350MCM-#6	250MCM-#6	600MCM-#4	4x600MCM-#2
225	LN1	1800 [820]	1180W	4200W	3.2-4.5%	< 1.0%	< 0.5%	2x600MCM-#2	600MCM-#2	600MCM-#2	2x350MCM-#6	8x350MCM-#6
300	LN2	2500 [1135]	1470W	5500W	3.2-4.5%	< 1.0%	< 0.5%	Copper Pad	Copper Pad	Copper Pad	Copper Pad	Copper Pad
500	LN3	3500 [1588]	1600W	10000W	4.5-6.0%	< 1.5%	< 1.0%	Copper Pad	Copper Pad	Copper Pad	Copper Pad	Copper Pad

1. Secondary winding group X lags primary group H by the angular displacement. Secondary group Y lags secondary group X by a further 30 degrees.

2. Estimated Values.

3. For additional information refer to: Typical Specifications, Technical Guide, Internal Layout and Connection Diagrams.

4. Specifications are subject to change without notice.

5. Based on primary side kVA rating and measured with all secondaries short circuited.

6. Based on kVA rating of one secondary and measured with only one secondary short circuited.

7. Enclosure sizes may vary depending on temperature rise. [80°C] temp. rise is not available for 500kVA H2T. 15kVA and 30kVA transformers have 200°C insulation class.

