



Energy Savings with an Energy Star Compliant Harmonic Mitigating Transformer

Tony Hoevenaars, P.Eng,
Vice President
Mirus International Inc.

The United States Environmental Protection Agency's Energy Star program has gained tremendous popularity since its inception in 1992. The Energy Star label is now recognized by many as a sign of energy efficiency as it appears across more than 30 different product areas such as computer equipment and household appliances. As society continues to work towards environmentally friendly and self sustaining energy solutions, this trend will certainly continue.

In 1998 Energy Star expanded its program to include Commercial and Industrial (C&I) transformers. A voluntary efficiency standard developed by the National Electrical Manufacturers Association (NEMA), known as NEMA TP 1-1996, *Guide for Determining Energy Efficiency for Distribution Transformers*, was adopted for the program. States such as Massachusetts, Wisconsin, Minnesota, California, New York and most recently Oregon and Hawaii, have established NEMA TP 1 in their state minimum efficiency standards or now include TP 1 as a provision in their commercial energy codes¹.

It is important to note that the NEMA TP-1 standard was based upon linear loading and is optimized for 35% load levels. This criteria has merit when the load is, in fact, linear because surveys have shown that many distribution transformers in North America are only lightly loaded. However, if the transformer is more heavily loaded and/or its load is primarily non-linear, designing to optimal efficiencies at 35% linear load may actually result in higher losses and lower efficiencies.

Since non-linear loads, which include computers, variable frequency drives and other power electronic equipment now constitute a very large component of today's load, simply meeting NEMA TP 1 and Energy Star compliance is often not a sufficient means of assuring optimal efficiency levels are met. This is because non-linear loads can very significantly increase harmonic losses and NEMA TP 1 was not intended to address these additional losses. As a result, transformers

designed for non-linear loads, such as K-rated and Harmonic Mitigating, are specifically exempted in NEMA TP 1. And since most loads today are non-linear, this means that meeting TP 1 and Energy Star compliance, in itself, will not ensure that optimal efficiency is achieved in many actual applications.

To address this, Mirus International has developed a line of Harmonic Mitigating Transformers (HMT's) that ensure optimal efficiency levels are reached with either linear or non-linear loading and at lightly loaded or heavily loaded levels. This is accomplished through two principle strategies: (i) transformer windings which are configured such that critical harmonics are cancelled within the transformer secondary and (ii) linear load efficiencies which meet NEMA TP 1 levels, not only at 35% load, but in the full operating range from 35% to 65%.

NEMA TP 1-1996 Transformer Efficiency Standard

NEMA TP-1 defines minimum efficiency levels for transformers with linear loads at 35% loading. This criteria was chosen based on surveys which indicated that the average loading on distribution transformers in North America is about 35%. The efficiency limits vary by transformer size but are generally in the 98% range. In choosing 35% loading, NEMA TP-1 puts extra emphasis on no-load (core) losses rather than load (copper) losses. With emphasis on no-load losses, NEMA TP-1 does not adequately address harmonic losses and therefore, specifically exempts transformers which service non-linear loads. The following are taken from its exemption list:

- c. Drives transformers, both AC and DC²
- d. All rectifier transformers and transformers designed for high harmonics
- g. Special impedance, regulation and harmonic transformers

The reason that transformers designed for high harmonics are exempted is that harmonics will

dramatically increase load losses (I^2R and eddy current) and have very little effect on no-load losses. Therefore, NEMA TP-1's emphasis on no-load losses can be counter productive when supplying non-linear loads. To meet the efficiency limits, a manufacturer must optimize for lower no-load losses, often at the expense of higher load losses. For example, one common way of reducing no-load losses is to reduce the flux density by adding more steel to the transformer's core. With a larger core, each turn of the transformer's windings must cover a larger circumference. The extra length of copper winding adds resistance which increases I^2R load losses. This can significantly INCREASE losses and REDUCE efficiencies when supplying non-linear loads at load levels above 35%.

Why Design for Peak Efficiency over a Load Range of 35% to 65%?

NEMA TP 1's emphasis on linear load efficiency under lightly loaded conditions is justified only if the power system is indeed lightly loaded and consists primarily of linear loads. If the load is non-linear or the system is more heavily loaded, optimizing efficiency at 35% can prove to be an inferior design resulting in higher losses rather than lower ones.

This problem can be averted if the transformer is designed for optimum efficiency over a wider load range and if its windings are configured to reduce harmonic losses. Figure 1 provides linear load efficiency curves for a standard 75 kVA Energy Star compliant TP 1 delta-wye transformer and for a 75 kVA Energy Star compliant Harmony-1E Harmonic Mitigating Transformer. Both meet the

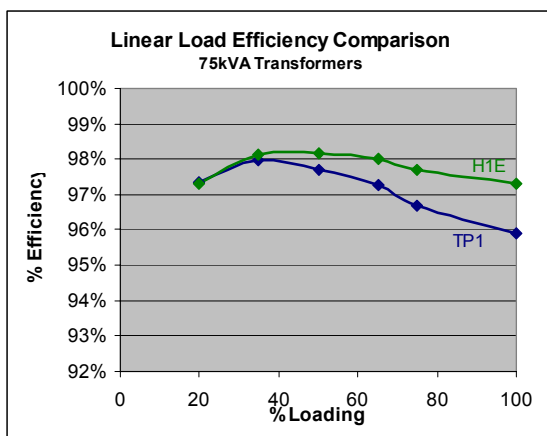

Figure 1: Linear load efficiency comparison

NEMA TP 1 efficiency limit of 98% at 35% linear load but the efficiency of the standard unit drops off rapidly under more severe loading. By maintaining TP 1 efficiency over the entire range from 35% to 65%, the Harmony-1E is more efficient at all load levels above 35%.

This improved performance is magnified when the load is non-linear. In Figure 2, non-linear load efficiencies are shown using the same transformers but with a K-9 load profile (I_{thd} = 80%) which is typical of computers and other 120V power electronic equipment. Under this loading, the Harmony-1E provides significantly more energy savings especially as the load increases on the transformer.

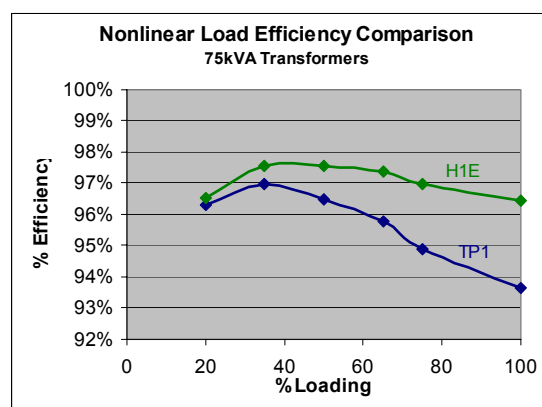

Figure 2: Non-linear load efficiency comparison

How Harmonics Increase Transformer Losses

Harmonics generated by non-linear loads will dramatically increase the losses in a conventional delta-wye distribution transformer. These added losses increase the monthly utility bill, indirectly add to environmental pollution and can shorten the transformer life by increasing its operating temperature.

To address the overheating transformer problem, K-rated delta-wye transformers are now frequently used in non-linear load applications. These transformers are designed to withstand the additional heat generated by the harmonic losses but will actually reduce these losses only marginally. Harmonic Mitigating Transformers, on the other hand, substantially reduce harmonic generated losses by using winding configurations that promote harmonic flux cancellation.

Transformer loss components include no load (P_{NL}) and load losses (P_{LL}). The no load losses are transformer core losses. They are essentially independent of the load current and its harmonic content. Furthermore, no load losses are affected only marginally by voltage harmonic distortion and therefore, can usually be neglected when determining the effect of harmonics on transformer losses. Load losses however, vary with the square of the load current and are very significantly affected by harmonic content.

Load losses consist primarily of I^2R copper losses (P_R) and eddy current losses (P_{EC}). Harmonics increase these losses in the following ways:

1. Copper Losses, I^2R

Harmonic currents are influenced by a phenomenon known as skin effect. Since they are of higher frequency than the fundamental current they tend to flow primarily along the outer edge of a conductor. This reduces the effective cross sectional area of the conductor and increases its resistance. A higher resistance leads to higher I^2R losses. Proximity effect between adjacent conductors compounds this problem by further distorting the current distribution in the conductors.

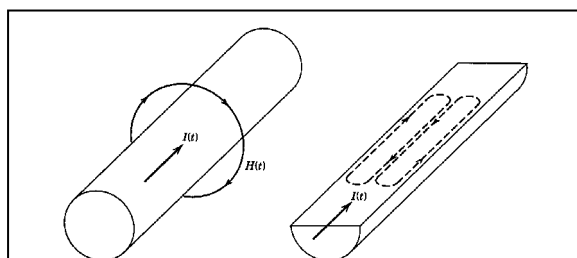

Figure 3: Skin effect in a conductor³

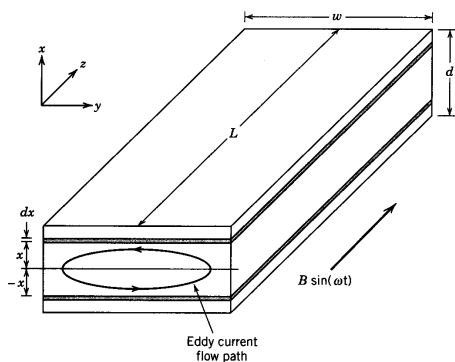

Figure 4: Eddy currents in the steel laminations of a transformer³

2. Eddy Current Losses

Stray electromagnetic fields will induce circulating currents in a transformer's windings, core and other structural parts. These eddy currents produce losses which increase substantially at the higher harmonic frequencies. The relationship is as follows:

$$P_{EC} = P_{EC-R} \sum_{h=1}^{h_{max}} I_h^2 h^2$$

Where:

P_{EC} = Total eddy current losses for non-linear load

P_{EC-R} = Eddy current losses at rated linear load

I_h = Ratio of rms current at harmonic h to full load current of transformer

h = harmonic #

For linear loads, eddy currents are a fairly small component of the overall load losses (approx. 5%). With non-linear loads however, they become a much more significant component, sometimes increasing by as much as 15 to 20x.

In addition to increasing conventional losses in a transformer, phase-to-neutral non-linear loads will also produce excessive primary winding circulating currents. The 3rd and other odd multiples of the 3rd harmonic (referred to as triplens) are zero phase sequence in nature and as such become trapped in the primary delta windings of conventional and K-rated transformers. I^2R and eddy current losses increase as these currents circulate in the transformers primary windings.

How HMT's Reduce Harmonic Losses

Harmonic Mitigating Transformers save energy by reducing losses in the following ways:

1. Zero phase sequence harmonic fluxes are cancelled by the transformers secondary windings. This prevents triplen harmonic currents from being induced into the primary windings where they would circulate. Consequently, primary side I^2R and eddy current losses are reduced.
2. Multiple output HMT's cancel the balanced portion of the 5th, 7th and other harmonics

within their secondary windings. Only residual, unbalanced portions of these harmonics will flow through to the primary windings. Again I^2R and eddy current losses are reduced.

3. HMT's are designed to be highly efficient at 60Hz as well as at harmonic frequencies. Energy Star compliant models meet NEMA TP-1 energy efficiency minimums at 35% loading. This is typically achieved by reducing core losses but not at the expense of higher copper losses.

Calculating Transformer Losses under Non-Linear Loading⁴

Calculating transformer losses under non-linear loading is a fairly complex process. The following procedure is commonly followed:

1. Determine the core loss at fundamental (60 Hz) frequency - P_{NL} .
2. Calculate I^2R losses in both the primary and secondary windings - P_R .
 - a) Determine the AC resistance at the fundamental frequency for the specific wire size and material used in the primary and secondary windings.
 - b) Determine the effective AC resistance due to skin effect at each of the harmonic frequencies.
 - c) Calculate the I^2R losses for each harmonic at the load K-factor chosen and the percent loading of the transformer.
 - d) Total all the I^2R losses
3. Calculate eddy current losses in both primary and secondary windings - P_{EC} .
 - a) Determine the eddy current loss at the fundamental frequency (P_{EC-1}). This is typically 5% of the I^2R loss at the fundamental frequency.
 - b) Calculate I^2h^2 for each harmonic at the load K-factor chosen and the percent loading of the transformer.
 - c) Calculate total eddy current losses by the following formula,

$$P_{EC} = P_{EC-1} \sum_{h=1}^{h_{max}} I_h^2 h^2$$

4. Total all loss components,
 $P_L = P_{NL} + P_R + P_{EC}$

Energy Savings Comparison

Figure 5 provides an example of the energy savings that can be realized when HMT's are used in lieu of conventional or K-rated transformers. A K-9 load profile, typical of a high concentration of computer equipment (I_{thd} = 80%), was selected for the analysis. Losses were calculated for various types of 75 kVA transformers at varying load conditions. In the graph, Conv is a conventional delta-wye transformer, K-13 is a K-13 rated delta-wye and H1E is a Harmony-1E™ single output Energy Star compliant HMT.

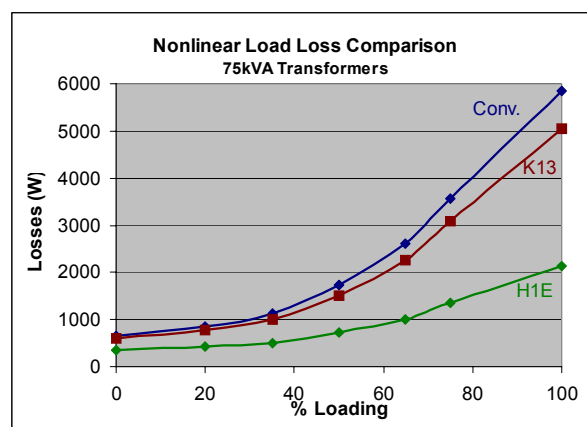

Figure 5: 75 kVA Transformer losses at various loading conditions with non-linear K-9 load profile.

The chart shows how energy savings become more and more substantial as a transformer's load increases. This is logical since it is the load losses which are most affected by the harmonic currents and these are proportional to the square of the current (I^2R and I^2h^2).

Figure 6 further emphasizes how transformer efficiencies are affected by non-linear loading. It compares the performance of various types of transformers with linear loading (K-1) and non-linear loading (K-9). The efficiencies of the conventional and K-13 transformer are much lower when they are subjected to a load with a K-9 profile, especially under the heavier loading conditions.

Determining the amount of energy savings associated with a reduction in harmonic losses requires information on the Electric Utility rate and the load's operating profile. These parameters can vary quite substantially depending upon the location of the facility and the specific application.

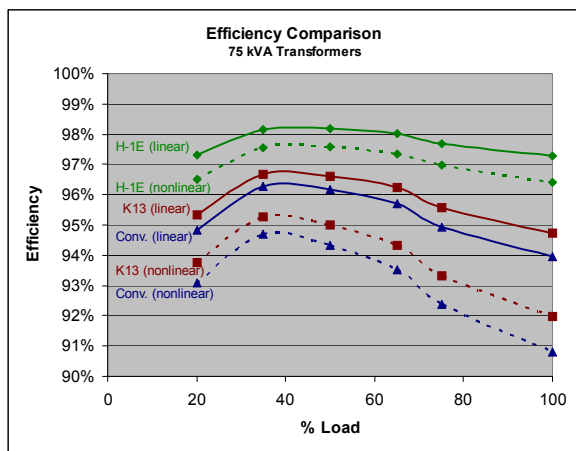

Figure 6: Energy Efficiencies for various types of 75 kVA transformers supplying linear (K-1) loads and non-linear (K-9) loads under varying load conditions.

is required by the building’s air conditioning system to remove the heat produced by the transformer losses. The calculation used is shown below the table.

This scenario could be typical of an office environment with a high concentration of computer loads and with the transformer located in air conditioned space. The requirement to cool the heat produced by the transformer’s losses is typically 30% to 40% of the power in the losses (thus the 1.35 multiplier in calculation of \$/yr Savings). Paybacks were calculated based on estimated transformer costs and would result in recovering the Harmony-1E premium many times over based on the transformer’s life expectancy of 30 to 40 years.

Table 1 shows the energy savings that can be realized when a Harmony-1E HMT is compared with a typical K-13 transformer. As in the previous examples, the transformers are 75 kVA and the non-linear load profile is that of a typical K-9 load. The monetary savings are based on the equipment operating 12 hours per day, 260 days per year at an average Utility rate of \$0.07 per kWhr and assumes that additional cooling energy

Table 2 provides another example. In this case, a lower harmonic content K-4 load profile was used with the equipment operating 24 hrs/day, 365 days a year and the transformer located in air conditioned space. An example of such a location might be a Broadcasting Facility or Data Center. As can be seen, paybacks are even more attractive.

Transformer	% Load	Losses (Watts)			Annual Consumption		Transformer Cost (Est.)	Payback on HMT Premium
		NLL	LL	Total	(kWhrs)	(\$ / yr)		
K-13	35%	590	411	1001	3,866	\$365	\$2,750	
	50%	590	928	1518	5,478	\$518		
	65%	590	1668	2258	7,787	\$736		
	100%	590	4445	5035	16,453	\$1,555		
Harmony-1E	35%	345	165	510	2,025	\$191	\$3,530	4.5 yrs
	50%	345	373	718	2,674	\$253		2.9 yrs
	65%	345	671	1016	3,606	\$341		2.0 yrs
	100%	345	1794	2139	7,109	\$672		0.9 yrs

Table 1: HMT energy savings and payback estimate comparing a 75 kVA HMT to a K-13 transformer in a typical office environment with a high concentration of computer equipment

$$Annual\ Consumption = (Total\ losses\ in\ kW) \times (hrs/day) \times (days/yr) + (NL\ loss\ in\ kW) \times (24 - hrs/day) \times (365 - days/yr)$$

$$$/yr\ Savings = (H1E\ Annual\ Consumption - K13\ Annual\ Consumption) \times 1.35 \times (rate\ in\ $/kWhr)$$

Transformer	% Load	Losses (Watts)			Annual Consumption		Transformer Cost (Est.)	Payback on HMT Premium
		NLL	LL	Total	(kWhrs)	(\$ / yr)		
K-13	35%	590	367	957	8,381	\$792	\$2,750	
	50%	590	835	1425	12,482	\$1,180		
	65%	590	1508	2098	18,381	\$1,737		
	100%	590	4054	4644	40,681	\$3,844		
Harmony-1E	35%	345	164	509	4,458	\$421	\$3,530	2.1 yrs
	50%	345	374	719	6,302	\$596		1.3 yrs
	65%	345	678	1023	8,958	\$847		0.9 yrs
	100%	345	1827	2172	19,024	\$1,798		0.4 yrs

Table 2: HMT energy savings and payback estimate comparing a 75 kVA HMT to a K-13 transformer in a typical Broadcasting Facility or Data Center

Summary

In summary, the inherent ability of Harmonic Mitigating Transformers to cancel harmonic currents within their windings can result in quantifiable energy savings when compared with the losses that would exist if conventional or K-rated transformers were used. If we consider the average premium cost of an HMT over a K-13 transformer, the typical payback in energy savings is 1 to 4 years when loading is expected to be in the 50% to 65% range. This, in itself, can be justification for the use of HMT's but when consideration is also given to the power quality improvement they provide by eliminating voltage distortion in the form of flat-topping, their use becomes even more easily justified.

For the most optimal energy efficiency design, Mirus' Energy Star compliant Harmony-1E™ HMT meets NEMA TP-1 minimum efficiencies at not only 35% load but also across the entire operating range from 35% to 65%. In this manner, energy savings can be assured not only at lightly loaded conditions but also at more

heavily loaded conditions whether the loads are harmonic generating non-linear in nature or simply linear.

References:

1. CEE Update, *News for Stakeholders in CEE's High-Efficiency C&I Transformer Initiative*, March 2002
2. NEMA TP 1-2002, *Guide for Determining Energy Efficiency for Distribution Transformers*, National Electrical Manufacturers Association, p 1
3. N. Mohan, T. Undeland, W. Robbins, *Power Electronics - Convertors, Applications and Design*, John Wiley & Sons Inc., New York, 1995, pp 748-754
4. T.S. Key, J.S La, *Costs and Benefits of Harmonic Current Reduction for Switch-Mode Power Supplies in Commercial Office Building*, IEEE Transactions on Industry Applications, Vol. 32, No. 5 Sept/Oct 1996, pp. 1017-1024
5. ANSI/IEEE C57.110-1986, *Recommended Practice for Establishing Transformer Capability When Supplying Nonsinusoidal Load Currents*, American National Standards Institute