

HARMONY™ Series Transformers



Benefits:

- Prevent voltage flat-topping while reducing energy costs.
- Reduce voltage distortion caused by harmonic currents
- Reduce current distortion at UPS, generator or utility service
- Improve Electromagnetic Compatibility with non-linear loads
- Electrostatic shielding for high frequency noise attenuation

HARMONY-1™

Energy efficient Harmonic Mitigating Transformer (HMT) having one 3-phase, 4-wire output with low zero sequence impedance. Prevents voltage distortion (flat-topping) and reduces harmonic losses that result when conventional or K-Rated transformers are used to supply single-phase non-linear loads, such as personal computers. Treats triplen harmonics (3rd, 9th & 15th) within the secondary windings and 5th and 7th harmonics upstream.

HARMONY-2™

Dual output, phase shifting, energy efficient HMT with low zero sequence impedance. Provides extremely low output voltage distortion and input current distortion even under severe non-linear loading conditions (Data Centers, Internet Service Providers, Telecom sites, etc.) Treats 3rd, 5th, 7th, 9th, 15th, 17th & 19th harmonics within its secondary windings. Available in two models for further cancellation of 11th & 13th harmonic currents upstream.

HARMONY-3 & 4™

Three and four output, energy efficient, phase shifting HMT's with low zero sequence impedance. Features ultra low output voltage distortion and input current distortion by treating 3rd, 5th, 7th, 9th and other higher harmonics within its secondary windings.

Background

Before the heavy use of power electronics, most loads were linear in nature producing very little harmonic current. This allowed for fairly easy selection of a distribution transformer for a particular application. Some of the selection criteria included:

1. *kVA requirement of the load with consideration for both future growth and load diversity.*
2. *Primary and secondary voltage requirements.*
3. *Choice of 3 or 4-wire primary and secondary winding configurations. Typically a delta-wye transformer configuration was used to permit both line-to-line and line-to-neutral loads.*
4. *Fault level considerations which would determine transformer impedance requirements.*

With the introduction of the switch-mode power supply (SMPS) found in personal computers and other 1-phase power electronic loads and the increasing use of 3-phase rectifiers (variable speed drives, UPS systems, etc.) transformer selection has become significantly more complicated. Electrical systems with conventional transformers are generally not suited to handle the harmonics generated by these non-linear loads and can have many safety, reliability, and power quality problems. Examples are:

1. *Triplen harmonic currents (3rd, 9th & 15th) circulate in the primary delta windings of the transformer increasing voltage distortion (flat-topping) and power losses.*
2. *Transformer losses, especially eddy current, increase due to the higher frequency harmonic currents. The excessive losses increase operating costs and can cause transformer failure at less than full rated loading.*
3. *Voltage distortion will develop as the harmonic currents pass through the transformer impedance. Other system impedances will also contribute to voltage distortion especially when the supply is a weak source such as a diesel generator or UPS system.*

To address the non-linear load challenge, the electrical industry's first response has been to double the neutral conductor rating and to specify the use of k-factor rated transformers. The k-factor rated transformer is basically a more conservatively designed delta-wye transformer which can better survive the additional losses created by the presence of harmonic currents.

High Voltage Distortion can lead to:

1. *Hardware failures and equipment downtime*
2. *Electronic equipment malfunction*
3. *Reduced equipment ride-through*
4. *Motor burnout*
5. *Communications errors*
6. *PF correction capacitor failure*
7. *Diesel generator misoperation*
8. *Problems transferring between emergency power source and utility*

However, from a power quality perspective, they do not offer any significant advantage over a standard delta-wye. Both the k-factor and the standard delta-wye transformer deal with the triplen current harmonics in the same manner, by allowing their balanced portion to circulate in the delta primary. This blocks the major portion of the triplen harmonics from flowing on the primary side feeder but has the distinct disadvantage of increasing triplen harmonic voltage distortion and losses in the primary side windings. Through the use of flux cancellation techniques at their secondary windings, MIRUS HARMONY™ transformers block the balanced portion of the triplen harmonic currents without circulating them in the primary windings. This avoids the triplen harmonic voltage distortion and losses which otherwise would occur.

Where to Apply Harmony™ HMT's:

- *Commercial buildings where PC's are prevalent*
- *Tenant fit-up or new construction*
- *Broadcasting & telecommunication sites*
- *Computer rooms and LAN rooms*
- *Financial Institutions*
- *Software development labs*
- *Computer labs in schools*
- *Semiconductor and other high-tech manufacturing facilities*
- *Downstream of UPS and Diesel Generators*

Typical Non-linear Load Harmonics

In order to logically select the appropriate MIRUS HARMONY™ Series transformer while ensuring that safety, reliability and power quality issues are all addressed, it is helpful to have some knowledge of the harmonics which are likely to be present.

The exact values of the current harmonic amplitudes will rarely be known in the design stage. Nevertheless, it usually can be determined whether most of the non-linear load will be 120VAC, single-phase SMPS (a line-to-neutral load), 208V single-phase SMPS (a line-to-line load) or three-phase, 6-pulse rectifiers (an inherently balanced line-to-line load), or some combination thereof.

Line-to-neutral rectifier loads produce current harmonics 3rd, 5th, 7th, 9th and higher. The 3rd will be the largest and usually the most troublesome because the 3rd harmonic currents in the phase conductors sum arithmetically in the neutral conductor. This is the reason that the neutral current can be very high despite having balanced loads on the phases and why double ampacity neutrals are recommended. The 3rd, 9th and other odd multiples of the 3rd harmonic are often referred to as triplen harmonics. Since they are arithmetically additive as they return to the transformer in the neutral conductor, they are also referred to as zero sequence currents. Also, the impedance to the flow of zero sequence current is called the zero sequence impedance. Typical 120V line-to-neutral rectifier loads include PCs, monitors, printers, telecommunications equipment and broadcasting equipment.

Ideally, a transformer that services this type of load should be capable of treating the 3rd, 5th, 7th and 9th harmonics.

208V single-phase switch-mode power supplies also produce current harmonics 3rd, 5th, 7th, 9th and higher. However, if they are reasonably balanced across the 3 phases, the amplitude of 3rd and 9th harmonic currents present on the phase conductors will be small and because they are connected from line-to-line, these loads cannot contribute to the neutral current. The largest current and voltage harmonics will generally be the 5th followed by 7th. The 11th and 13th will also be present. Typical 1-ph, 208V rectifier loads include larger computer equipment and their peripherals. Transformers that service phase-phase non-linear loads should be capable of treating at least the 5th and 7th harmonics.

208V 6-pulse rectifiers are inherently balanced so that they do not draw 3rd and 9th harmonic current provided that the supply voltage is balanced. They also do not contribute to the neutral current because they are not connected to it. The principal harmonics will be the 5th followed by the 7th with 11th and 13th also present. Typical 3-ph, 208V rectifier loads are found in variable speed drives and Uninterruptible Power Supplies (UPS). Transformers that service 3-phase non-linear loads should be capable of treating at least the 5th and 7th harmonics.

Occasionally a 208V, 12-pulse rectifier may be encountered. In this case the lowest characteristic harmonics will be the 11th and 13th. The 12-pulse rectifier is more common in large installations at 480V and 600V.

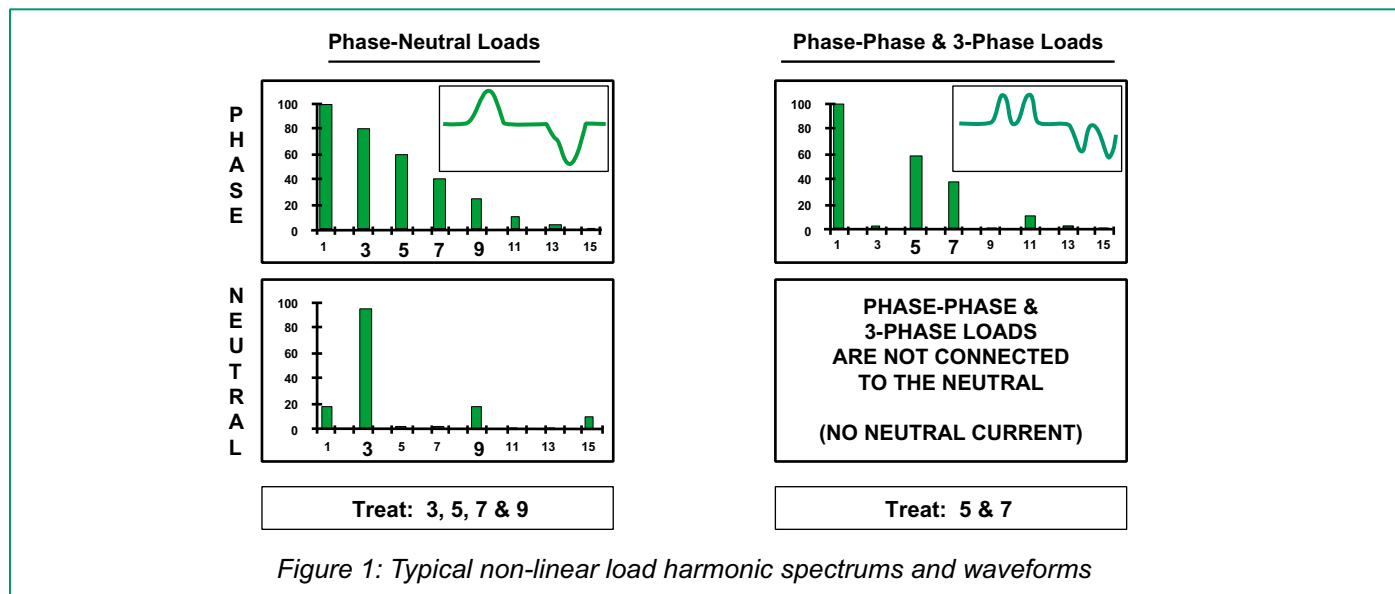

Harmonic Mitigating Transformers will reduce Voltage Distortion and Flat-topping

Prevention of voltage distortion is important because it decreases the degree of supply voltage flat-topping (loss of peak-to-peak voltage) seen by the switch-mode power supplies (SMPS) in non-linear loads. It is not uncommon to find distribution systems with conventional or k-factor delta-wye transformers where the RMS voltage is only marginally low but the peak voltage is more than 10% low.

Voltage flat-topping is the most common form of voltage distortion and can be explained most simply by analyzing the current and voltage time domain waveforms (see Figure 2). Since a switch-mode power supply draws current only at the peak of the voltage waveform (to charge the smoothing capacitor), voltage drop due to system impedance, will occur only at the peak of the voltage waveform. A flattened voltage peak will reduce the DC bus voltage within the SMPS and can lead to component overheating and premature equipment failure.

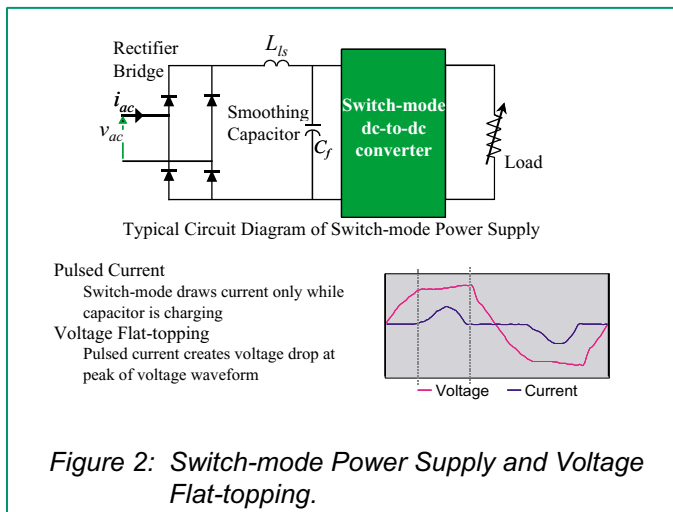

One of the consequences of this voltage flat-topping is an increase in losses within the SMPS itself. For example, a 10% decrease in peak voltage (from 169.4V to 153V) will increase the SMPS line current by about 11% which will in turn increase the I^2R portion of the SMPS losses by about 23% (see Figure 3). In addition, a 10% reduction in peak voltage will also reduce the power dip ride-through time of the computer load by about 37%. Overall system reliability can be improved by simultaneously maintaining the correct level of both RMS and peak voltage to the power supplies of the computer room and PC systems.

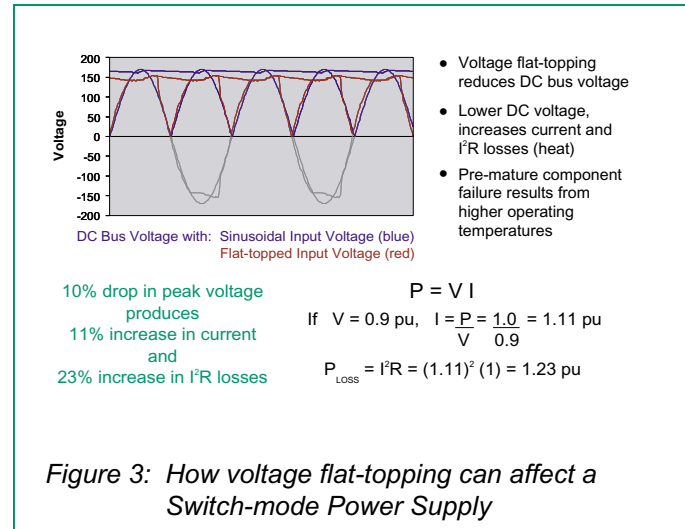

The amount of voltage distortion, V_{thd} , in a power system follows Ohm's Law ($V_h = I_h \times Z_h$) where:

$$\begin{aligned} V_h &= \text{voltage at harmonic number } h \\ I_h &= \text{amplitude of current harmonic } h \\ Z_h &= \text{impedance of the system to harmonic } h. \end{aligned}$$

The voltage total harmonic distortion is:

$$V_{\text{thd}} = \frac{\sqrt{V_2^2 + V_3^2 + \dots + V_h^2}}{V_1} \times 100\%$$

(see Figure 4)

In other words, voltage distortion due to harmonic currents consists of voltage drops which occur at other than the fundamental frequency (usually 60Hz in North America).

Voltage distortion can be minimized by removing the harmonic currents (I_h) and/or lowering the system impedance (Z_h) to the harmonics. (For further information on the relationship between voltage drop and voltage distortion and how to minimize them, we recommend two MIRUS technical papers titled (1) "Taming the Rogue Wave - Techniques for Reducing Harmonic Distortion" and (2) "How the Harmonic Mitigating Transformer Outperforms the K-Rated Transformer".)

Delta-wye transformers, even those with high k-factor rating, generally present a high impedance to the flow of harmonic currents returning from the non-linear loads. As a result, under rated loads, these transformers can produce critically high levels of voltage distortion and flat-topping at their outputs and at the downstream loads.

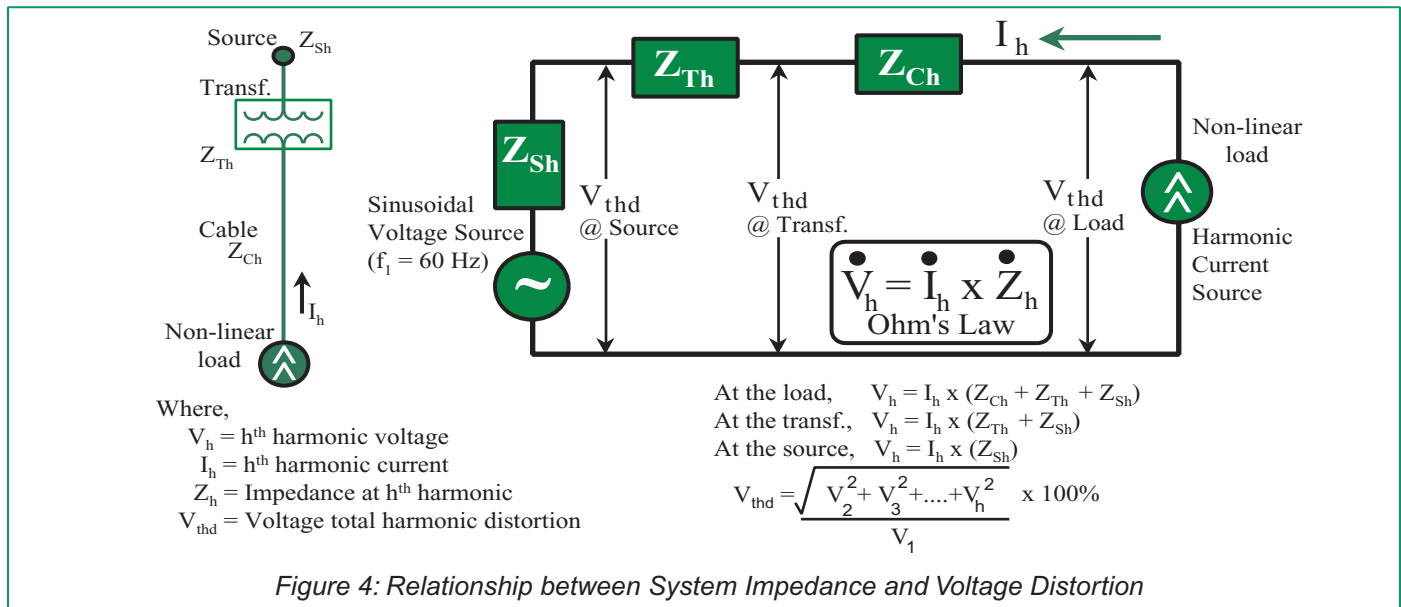

To minimize the voltage distortion that occurs within the transformer itself, all HARMONY™ Series transformers are designed with reduced impedance to the flow of harmonic currents. This is accomplished through zero sequence flux cancellation and phase shifting - a combined strategy pioneered by MIRUS. The cancellation of zero sequence fluxes (those produced by the 3rd, 9th, 15th ... harmonics) in the secondary windings of a HARMONY™ transformer prevents these

harmonics from circulating in the primary windings. This results in a much lower impedance and lower voltage distortion at these harmonics. In addition, the reduced primary winding circulating current will reduce losses and allow the transformer to run much cooler. The remaining harmonics (5th, 7th, 11th, 13th, 17th & 19th) are treated to varying degrees through the introduction of phase shifts in the various HARMONY™ series models.

Harmony-1™ Transformer

The HARMONY-1™ transformer has one 3-phase, 4-wire secondary with very low zero phase sequence impedance which minimizes the voltage distortion at the triplen harmonics (3rd, 9th, 15th). This is achieved through zero sequence flux cancellation within the secondary windings of the Harmony-1™. This prevents these harmonics from coupling to, and circulating in, the primary winding as they would in a delta-wye k-factor transformer. As a result, both triplen harmonic voltage distortion and power losses are much lower.

The HARMONY-1™ is available with either 0° or 30° phase shift angle between the primary and secondary windings. When two HARMONY-1™ transformers are electrically connected to the same primary bus, choosing one transformer with 0° phase shift and a second transformer with 30° phase shift will produce cancellation of the balanced portion of the 5th, 7th, 17th and 19th harmonic currents at this primary bus. This in turn will reduce harmonic voltage distortion created by the harmonic current flow in the primary system impedance. The reason these particular harmonics will cancel is that a 30° phase shift at 60Hz produces a 180° phase shift

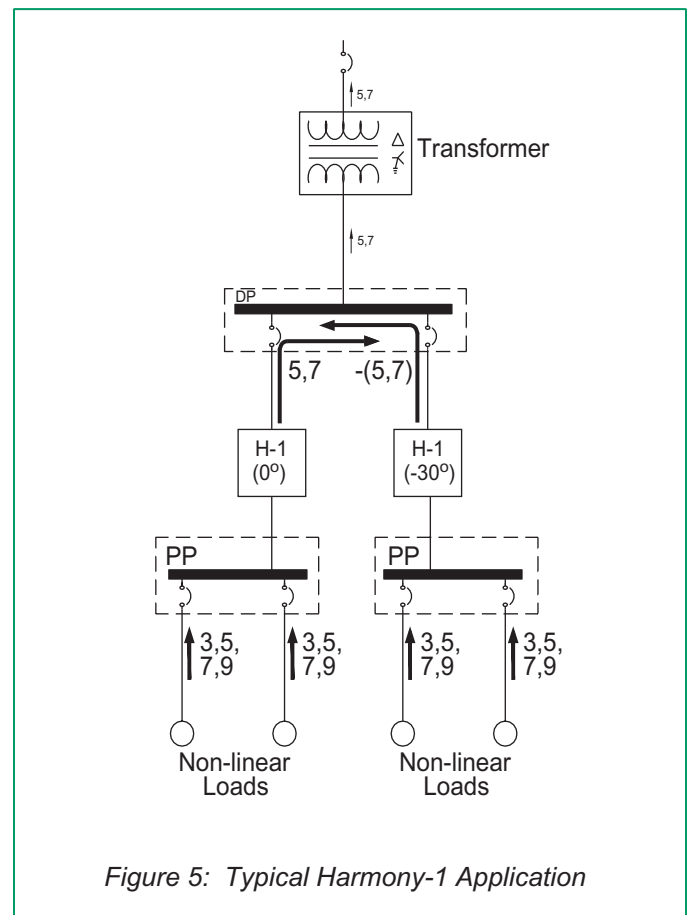

at each of the 5th, 7th, 17th and 19th harmonics. Therefore, the harmonic currents returning from the 30° HARMONY-1™ model will be directly out of phase with the unshifted harmonic currents returning from the 0° model. Cancellation occurs at the point where they meet upstream. It should be noted that the transformer itself typically presents a more significant impedance than does the primary system. Therefore under heavy non-linear loads with high levels of 5th and 7th current harmonics, voltage distortion may exceed IEEE Std 519-1992 recommended maximum levels at these harmonics. If this is the case, consideration should be given to the

use of multiple output HARMONY™ series transformers, such as the HARMONY-2, 3, or 4™.

One very suitable application for the MIRUS HARMONY-1™ occurs when expanding or renovating an existing system which has delta-wye transformers. The delta-wye transformer has an inherent 30° phase shift so the use of a HARMONY-1™ with 0° phase shift between primary and secondary windings will help reduce voltage distortion at the 5th, 7th, 17th and 19th harmonics in addition to reducing the triplen harmonic voltage distortion.

Harmony-2™ Transformer

The HARMONY-2™ transformer is equipped with dual 3-phase, 4-wire outputs. Each output has low zero phase sequence impedance which treats the triplen harmonics in much the same manner as the HARMONY-1™. In addition, there is a phase shift angle between the two outputs of 30° which cancels the balanced portion of 5th, 7th, 17th, and 19th current harmonic fluxes so that they are not coupled to the primary winding. This is equivalent to a 12 pulse rectifier where only residual amounts of these currents flow in the primary.

The HARMONY-2™ is also available in two model types - 0° and 15°. When multiple transformers are required, alternating between the two models will produce upstream cancellation of the 11th and 13th harmonic currents on the primary side common feeder in much the same manner as the HARMONY-1™ treats 5th and 7th harmonics. The net result is treatment of all the odd order harmonics from the 3rd through 21st.

In the standard HARMONY-2™ design, each secondary output is rated at 60% of the primary kVA rating. The NEC and CEC regard the reduced kVA rating of each secondary as a reduced ampacity conductor tap that must have suitable overcurrent protection within 25 cable feet of the transformer. Often this can be the input breaker in a distribution panel. For example, the 225A main CB in a 225A panel protects the 67.5kVA rating of the secondary of a 112.5 kVA MIRUS Harmony-2™ transformer (for recommended protection and cable sizing see Harmony-2™ Technical Data Sheet). Fully rated secondaries are available in sizes up to 150 kVA.

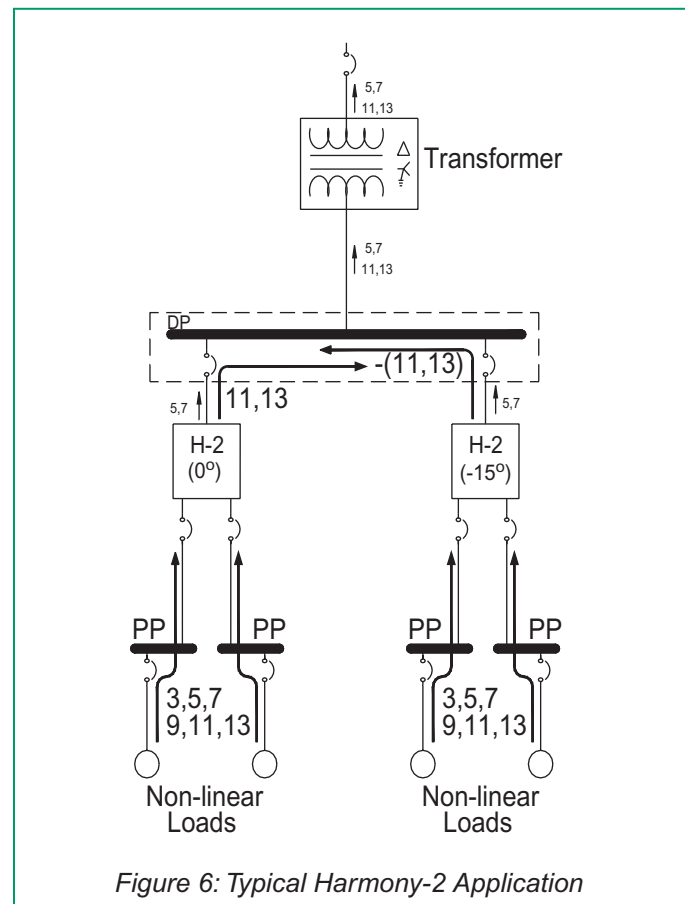

Figure 6: Typical Harmony-2 Application

For the most effective harmonic cancellation, the non-linear loads should be approximately balanced between the two outputs. However, as shown in Figure 7, excellent results can be achieved even when the loads cannot be well balanced. Under typical loading conditions, voltage distortion at the HARMONY-2™ output will not exceed 3%. A standard or k-rated transformer, on the other hand, would likely have voltage distortion at its output in the range of 6 - 10% under similar loading conditions.

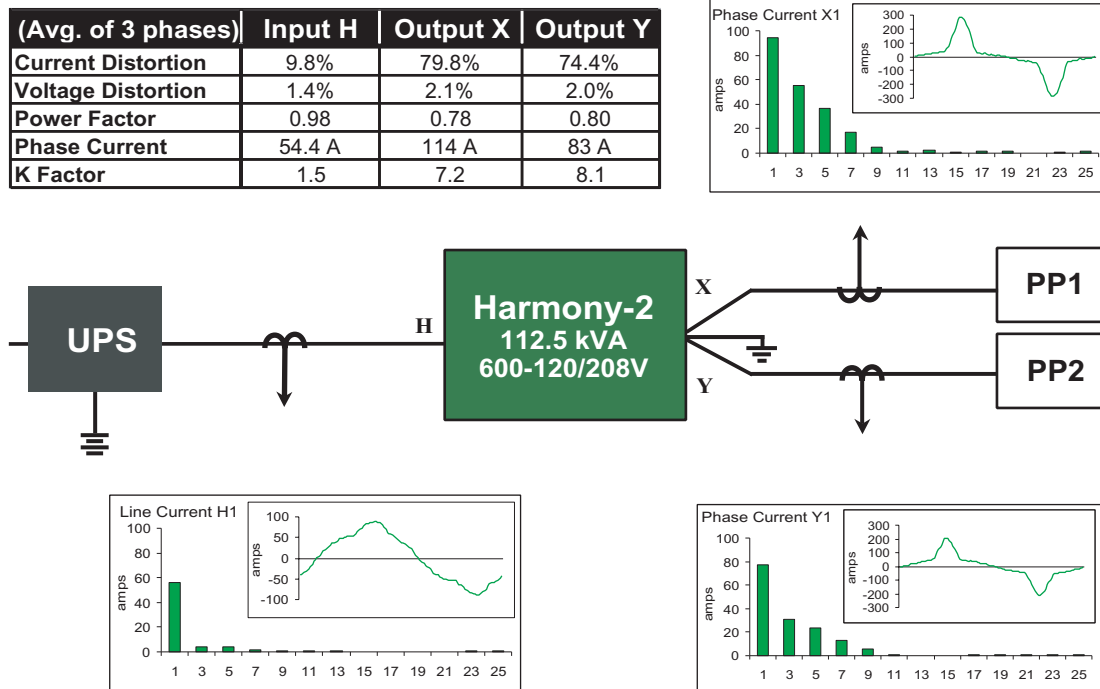

Figure 7: Typical HARMONY-2™ performance downstream of UPS

Harmony-3™ Transformer

The HARMONY-3™ transformer is designed to treat the 3rd through 15th harmonics through the use of 3 sets of 3-phase, 4-wire outputs. The 20° phase shift between these outputs will create an effective 18-pulse rectification scheme. As with all HARMONY™ Series transformers, each output has very low zero phase sequence impedance. This assures that the HARMONY-3™ transformer will reduce voltage distortion which would otherwise be created by the 3rd, 5th, 7th, 9th, 11th, 13th and 15th harmonic currents.

Recommended practice is to use each of the three outputs of the HARMONY-3™ to feed a separate power panel (equipped with appropriate main CB) feeding similar types of non-linear load. The standard design incorporates three secondary outputs, each rated at 40% of the primary kVA rating. As with the HARMONY-2™, appropriate overcurrent protection of each output is required within 25 cable feet of the transformer. A typical application of the HARMONY-3™ transformer is to feed three floors of a building with the transformer installed in the electrical room on the middle floor.

Harmony-4™ Transformer

Distributing harmonic loads between the four outputs of this transformer creates an effective 24-pulse scheme. Only residual traces of harmonic distortion remain because all harmonics less than the 23rd are treated. Normally, the high performance of a Harmony-4™ transformer is required only in very special applications, such as for systems with loads having high levels of the higher order harmonics or systems with loads that are especially sensitive to voltage distortion.

Harmony™ Autotransformers

If neither voltage transformation (ie. 480V to 120/208V) nor galvanic isolation (for noise attenuation) is required, then the autotransformer version of the Harmony-2, -3 or -4™ may be used to achieve the same impressive harmonic cancellation with a smaller size, weight and cost. An excellent application is downstream of a 120/208V 3-phase UPS system. Without this treatment, the high output impedance of a UPS inverter can cause excessive voltage distortion when feeding switch-mode power supplies.

ONICS™ Harmonic Mitigating Power Centers

For raised floor Data Center environments, the ONICS™ HMPC provides a packaged power distribution system which integrates a Harmony™ Harmonic Mitigating Transformer with noise suppression, electronic grade grounding, non-linear load distribution panels and optional TVSS, monitoring and alarms.



Figure 8 - ONICS HMPC

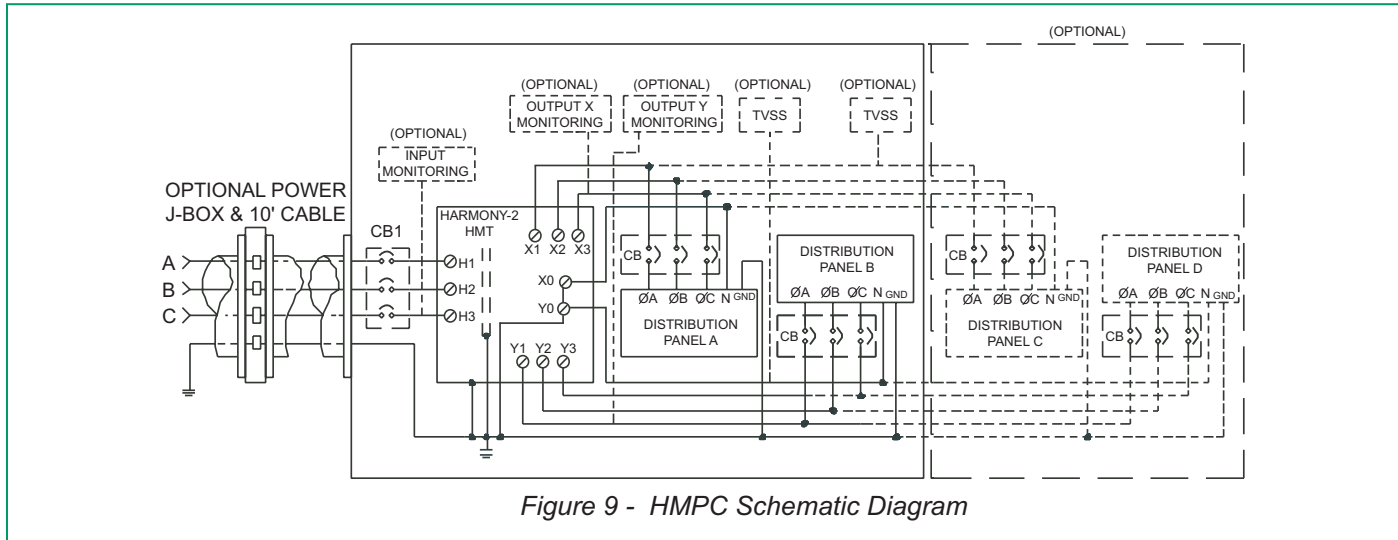

Figure 9 - HMPC Schematic Diagram

Further Design Strategies - Double neutral conductor ampacity and avoid long 120/208V, 4-wire distribution runs

It is important to remember that the non-linear loads are the source of the harmonic currents. They must flow from the loads back to the HARMONY™ series transformer before it can mitigate the harmonic induced ill effects (particularly voltage distortion) that would have appeared if ordinary k-factor transformers were used. Because the 3rd and 9th current harmonics created by the 120 VAC switch-mode power supplies are flowing back on the neutral, the neutral current is usually larger than the phase currents. As explained earlier, this is of little consequence provided the neutral has double ampacity and the 120/208V, 4-wire run length is not excessive. **Caution:** Do not forget when selecting phase and neutral conductor sizes that the electrical code requires that an ampacity adjustment or correction factor be applied when there are more than three current carrying conductors in a conduit. Ph.A, Ph.B, Ph.C and N are all current carrying conductors in non-linear load applications.

To minimize harmonic problems in new installations, avoid the old approach of using a large central transformer with a 120/208V secondary and long 4-wire risers or radial runs through the building. The impedances of these long runs are high so that harmonic currents flowing through these impedances will create high levels of voltage distortion and neutral-to-ground voltage (one form of common mode noise). To prevent these problems, an effective rule of thumb is to limit each 120/208V run length to that which would produce a 60Hz voltage drop not greater than 1/2% to 3/4%. For a typical 200 amp feeder this would be < 50 ft.

Combining the use of HARMONY™ series transformers with short 120/208V feeder runs and double ampacity neutrals will ensure compatibility between the distribution system and the non-linear loads. Generally this will keep voltage distortion safely below the maximum of 5% as recommended for sensitive loads in IEEE Std 519-1992.

Harmonic Mitigating Transformers and Energy Savings

Harmonics generated by non-linear loads will dramatically increase the losses in a conventional delta-wye or k-rated distribution transformer. These additional losses will result in significant energy waste. The triplen harmonic flux cancellation action of the Harmony™ series transformers gives them an inherent efficiency advantage over conventional and k-factor delta-wye transformers when feeding this type of non-linear load.

Transformer loss components include no load (PNL) and load losses (PLL). The no load losses are transformer core losses which are affected by harmonics only in relation to voltage distortion, not current distortion. Consequently, the increase in no load losses due to harmonics is usually negligible. Load losses however, are very significantly affected by harmonic currents.

Load losses consist primarily of I²R copper losses (PR) and eddy current losses (PEC). Harmonics increase these losses in the following ways:

1. Copper Losses, I²R

Harmonic currents are influenced by a phenomenon known as skin effect. Since they are of higher frequency than the fundamental current they tend to flow primarily along the outer edge of a conductor. This reduces the effective cross sectional area of the conductor and increases its resistance. The higher resistance will lead to higher I²R losses.

2. Eddy Current Losses

Stray electromagnetic fields will induce circulating currents in a transformer's windings, core and other structural parts. These eddy currents produce losses which increase substantially at the higher harmonic frequencies. The relationship is as follows:

$$P_{EC} = P_{EC-1} \sum_{h=1}^{h_{\max}} I_h^2 h^2$$

Where:

PEC = Total eddy current losses

PEC-1 = Eddy current losses at fundamental frequency (60Hz)

I_h = rms current at harmonic h

h = harmonic #

For linear loads, eddy currents are a fairly small component of the overall load losses (approx. 5%). With non-linear loads however, they become a

more significant component, sometimes increasing by as much as 15x to 20x.

In addition to increasing conventional losses in a transformer, phase-neutral non-linear loads will also produce excessive primary winding circulating currents. The 3rd and other triplen harmonics will become trapped in the primary delta windings of conventional and k-rated transformers. I²R and eddy current losses increase as these currents circulate in the transformers primary windings.

Harmonic Mitigating Transformers reduce harmonic losses in the following ways:

1. Zero phase sequence harmonic fluxes are canceled by the transformers secondary windings. This prevents triplen harmonic currents from being induced into the primary windings where they would circulate. Consequently, primary side I²R and eddy current losses are reduced.
2. Multiple output HMT's cancel the balanced portion of the 5th, 7th and other harmonics within their secondary windings. Only residual, unbalanced portions of these harmonics will flow through to the primary windings. Again I²R and eddy current losses are reduced.
3. Energy Star compliant models are available. Designed for optimum efficiency at 35% loading, Energy Star compliant designs reduce core losses to further improve efficiencies under lightly loaded conditions.

Figure 10 provides an example of the energy savings that can be realized when HMT's are used in lieu of conventional or k-rated transformers.

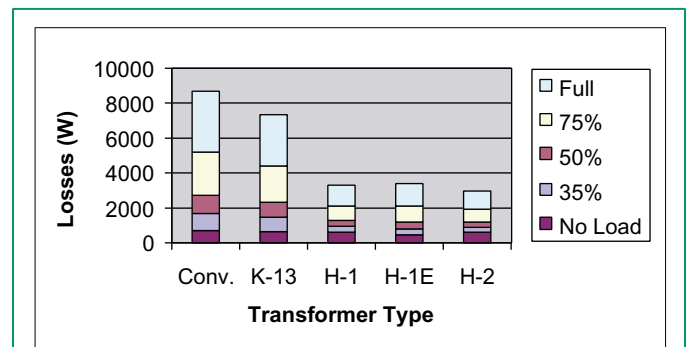

Figure 10: 112.5 kVA Transformer losses at various loading conditions with non-linear K-9 load profile.

Transformer	35% Load		50% Load		75% Load		100% Load	
	K-1	K-9	K-1	K-9	K-1	K-9	K-1	K-9
Conventional	96.2%	95.6%	96.4%	95.1%	95.6%	93.7%	94.5%	92.0%
K-13	96.9%	96.1%	97.1%	95.6%	96.6%	94.4%	95.9%	93.0%
Harmony-1	97.6%	97.6%	97.8%	97.7%	97.6%	97.5%	97.3%	97.1%
Harmony-1 Energy Star	98.2%	98.0%	98.0%	97.9%	97.7%	97.9%	97.3%	97.0%
Harmony-2	97.6%	97.8%	97.8%	98.0%	97.6%	97.9%	97.3%	97.6%

Table 1: Energy Efficiencies for various types of 112.5 kVA transformers supplying linear (K-1) loads and non-linear (K-9) loads under varying load conditions.

K-9 load profile, typical of a high concentration of computer equipment (I_{thd} = 80%), was selected for the analysis. Losses were calculated for various types of 112.5 kVA transformers at varying load conditions. In the chart, H-1 is the Harmony-1™ single output HMT, H-1E is the Energy Star compliant model of the Harmony-1™ and H-2 is the dual output Harmony-2™ HMT.

The chart shows how energy savings become more and more substantial as a transformer's load increases. This is logical since it is the load losses which are most affected by the harmonic currents and these are proportional to the square of the current (I^2R and I^2h^2). It also shows how a transformer that is optimized for 35% efficiency, such as the Energy Star model, is not necessarily the best design for reducing harmonic losses. Obtaining high efficiency designs at 35% loading requires that the no load core losses be reduced - sometimes at the expense of the load losses. Since no load losses are not influenced by current harmonics and load losses are, the advantages of the Energy Star design diminishes as loading increases.

Table 1 further emphasizes how transformer efficiencies are affected by non-linear loading. It compares the performance of various types of transformers with linear loading (K-1) and non-linear loading (K-9). The efficiencies of the conventional and K-13 transformer are much lower when they are subjected to a load with a K-9 profile, especially under the heavier loading conditions.

Determining the amount of energy savings associated with a reduction in harmonic losses requires information on the Electric Utility rate and the load's operating profile. These parameters can vary quite substantially depending upon the location of the facility and the specific application. Table 2 shows the energy savings that can be realized for 3 types of HMT's when compared with a typical K-13 transformer. As in the previous examples, the transformers are all 112.5 kVA and the non-linear load profile is that of a typical K-9 load.

The monetary savings are based on the equipment operating 12 hours per day, 260 days per year at an average Utility rate of \$0.07 per kWhr. The calculation is as follows:

$$\text{Annual Energy Savings} = (\text{Energy Savings in kW}) \times (\text{hrs/day}) \times (\text{days/yr}) \times (\text{rate in \$/kWhr})$$

It is worthwhile noting that if the transformer were located in air conditioned space, additional savings in reduced cooling costs (30% - 40%) would be realized.

In summary, the inherent ability of Harmonic Mitigating Transformers to cancel harmonic currents within their windings can result in quantifiable energy savings when compared with the losses that would exist if conventional or k-rated transformers were used. If we consider the average premium cost of an HMT over a K-13 transformer, the typical payback in energy savings is 3 - 5 years when loading is expected to be in the 50% - 75% range.

Transformer	% Load	Losses (Watts)	Energy Savings (Watts)	(\$ / yr)
K-13	50%	2852	n/a	n/a
	75%	5610	n/a	n/a
	100%	9470	n/a	n/a
Harmony-1	50%	1603	1249	\$273
	75%	2827	2783	\$608
	100%	4540	4930	\$1,077
Harmony-1 Energy Star	50%	1521	1331	\$291
	75%	2865	2745	\$600
	100%	4747	4723	\$1,032
Harmony-2	50%	1489	1363	\$298
	75%	2583	3027	\$661
	100%	4114	5356	\$1,170

Table 2: HMT energy savings comparing various types of 112.5 kVA HMT's to a typical K-13 transformer

HARMONY™ Series Products

MIRUS Transformer	Application Description
<p>HARMONY-1</p> <p>Harmonics Treated: 3rd, 9th, & 15th on secondary 5th, 7th, 17th & 19th upstream</p>	<ul style="list-style-type: none"> • Single 3-ph, 4-wire output with very low zero sequence impedance to minimize 3rd, 9th, and 15th harmonic voltage distortion. • Used in systems with non-linear, line-to-neutral loads with reasonably low levels of 5th & 7th harmonics. • Available with either 0° or 30° phase shift between primary and secondary. • Alternate 0° and 30° phase shift HARMONY-1 transformers on the same primary bus such that approximately 1/2 the load is fed from each unit. 5th, 7th, 17th, and 19th harmonic currents will cancel at this common bus. • On existing systems using delta-wye transformers with inherent 30° phase shift, the use of the HARMONY-1 with 0° phase shift during system expansion will help reduce voltage distortion of 5th, 7th, 17th, and 19th harmonics.
<p>HARMONY-2</p> <p>Harmonics Treated: 3rd, 5th, 7th, 9th, 15th, 17th & 19th on secondary 11th & 13th upstream</p>	<ul style="list-style-type: none"> • Dual 3-ph, 4-wire outputs with 30° phase shift between them. Each output has very low zero sequence impedance to minimize 3rd, 9th, and 15th harmonic voltage distortion. • A phase shift of 30° between the two outputs cancels the balanced portion of 5th, 7th, 17th, and 19th in the secondary winding of the transformer creating a 12-pulse scheme to minimize voltage distortion at the 3rd, 5th, 7th, 9th, 15th, 17th and 19th harmonics. • Available in either 0° or 15° phase shift models. • Alternating between 0° and 15° models on the same primary bus produces cancellation of 11th and 13th harmonic currents upstream. Effectively creating a 24-pulse scheme which reduces all harmonic distortion components below the 23rd harmonic. • The standard design incorporates two secondary outputs rated at 60% of the primary kVA rating. An overcurrent protection device must be installed within 25 cable feet of each transformer output as required by the electrical code. This can often be the main input circuit breaker of a distribution panel.
<p>HARMONY-3</p> <p>Harmonics Treated: 3rd, 5th, 7th, 9th, 11th, 13th & 15th on secondary</p>	<ul style="list-style-type: none"> • Three-output transformer with 20° phase shift between outputs used to create an 18-pulse scheme. Each output has very low zero sequence impedance. • Reduces current and voltage distortion created by 3rd, 5th, 7th, 9th, 11th, 13th, and 15th harmonic currents. • The standard design incorporates three secondary outputs rated at 40% of the primary kVA rating. An overcurrent protection device must be installed within 25 cable feet of each transformer output as required by the electrical code. This can often be the main input circuit breaker of a distribution panel. • A typical application of the HARMONY-3 transformer is to feed three floors of a building with the transformer installed on the middle floor.
<p>HARMONY-4</p> <p>Harmonics Treated: 3rd, 5th, 7th, 9th, 11th, 13th, 15th, 17th & 19th on secondary</p>	<ul style="list-style-type: none"> • Four-output transformer with 15° phase shift between outputs creating an effective 24-pulse system reducing current and voltage distortion for all odd order harmonics below the 23rd. • Each output has very low zero sequence impedance. • Each output is rated at 33% of the primary kVA rating and must have appropriate overcurrent protection.

Fault level will increase with the use of low zero sequence impedance Harmony Series products.
(See MIRUS 'Design Note #1' for more information on fault level calculations)

Typical Performance

Application Example

Output Voltage Distortion	Input Current Distortion	Neutral Current	Neutral-GND Voltage	Power Factor
---------------------------	--------------------------	-----------------	---------------------	--------------

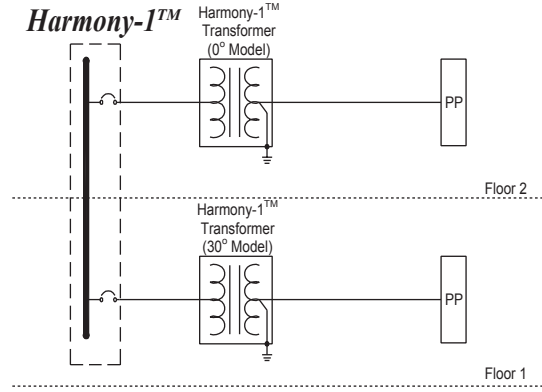

$V_{THD} = 2.5\% - 5\%$

$I_{THD} = 10\% - 25\%$

Double neutrals recommended

Short runs recommended

Above 90%

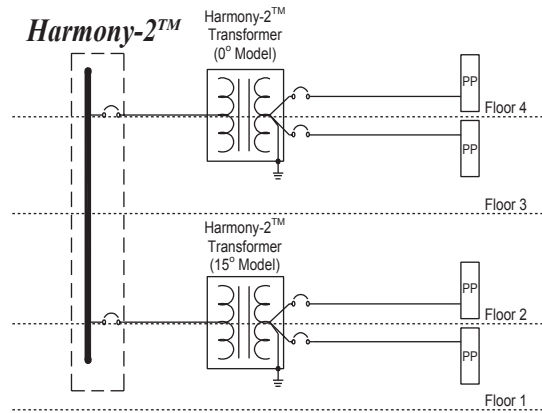

$V_{THD} = 1.5\% - 3.5\%$

$I_{THD} = 7\% - 15\%$

Double neutrals recommended

Short runs recommended

Above 95%

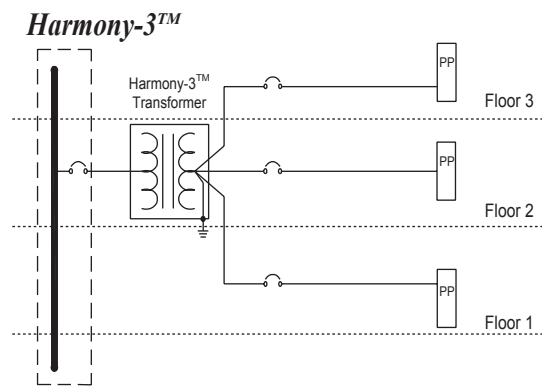

$V_{THD} = 1.0\% - 3.5\%$

$I_{THD} = 5\% - 12\%$

Double neutrals recommended

Short runs recommended

Above 95%

This guide illustrates the general application of MIRUS products only. To ensure proper implementation for a specific installation, please consult factory



MIRUS International Inc.
31 Sun Pac Blvd.
Brampton, Ontario
Canada L6S 5P6

Tel:(905) 494-1120 Fax:(905) 494-1140
Toll Free: 1-888-TO MIRUS
Email: mirus@mirusinternational.com
Website: www.mirusinternational.com



H-TG01-A2
Effective: August 2003